



P13114 23/03/05



**DECLARATION OF CONFORMITY**

Simba International Limited hereby declare that the Product described in this Operators Manual, and defined by the Serial Number Plate attached to the Chassis of the Machine (a part copy of which is detailed overleaf and must be completed indicating the relevant machine details), conforms with the following Directives and Regulations, and has been certified accordingly.

**EC Machinery Directive 89/392/EEC, as amended by 91/3688/EEC, 93/44/EEC, and 93/688/EEC.**

In order to fulfill the requirements of health and safety described in the EC Directive, the following standards and technical specifications have been taken into account:

**EN 292 - 1**  
**EN 292 - 2**

**THE MANUFACTURER**

Simba International Limited  
Woodbridge Road  
SLEAFORD  
NG34 7EW  
Lincolnshire  
NG34 7EW  
England.

Telephone 01529 304654.

**CERTIFIED ON BEHALF OF SIMBA INTERNATIONAL LIMITED.**

Philip J. Wright. BSc (Hons) C Eng. MI Agr.E  
Technical Director.



## **WARRANTY**

### **TERMS AND CONDITIONS**

In this warranty Simba International Ltd., is referred to as “the Company”.

1. Subject to the provisions of this warranty the Company warrants each new machine sold by it to be sold free from any defect in material or workmanship for a period of 12 months from date of installation with the end-user.

Some specific items have additional warranty over and above the standard 12 months. Details of these can be obtained upon request directly from the distributor or Simba International Ltd.

2. If the machine or part thereof supplied by the Company is not in accordance with the warranty given in clause 1 the Company will at its option:
  - (a) make good the machine or part thereof at the Company's expense, or
  - (b) make an allowance to the purchaser against the purchase price of the machine or part thereof, or
  - (c) accept the return of the machine and at the buyers option either:
    - I) repay or allow the buyer the invoice price of the machine or part thereof, or
    - II) replace the machine or part thereof as is reasonably practical.
3. This warranty shall not oblige the Company to make any payment in respect of loss of profit or other consequential loss or contingent liability of the Purchaser alleged to arise from any defect in the machine or impose any liability on the Company other than that contained in clause 2.
4. Any claim under this warranty must be notified to the Company in writing specifying the matters complained of within 14 days from the date of repair.
5. Any claim under this warranty must be made by the original purchaser of the machine and is not assignable to any third party.
6. If the purchaser hires out the machine to any third party the warranty shall apply only to matters notified to the Company in writing within 90 days of the date of delivery and clause 1 shall be read as if the period of 90 days were substituted for the period of 12 months.
7. The warranty will cease to apply if:
  - (a) any parts not made, supplied or approved in writing by the Company are fitted to the machine or
  - (b) any repair is carried out to the machine other than by or with the express written approval of the Company or
  - (c) any alterations not expressly authorized by the Company in writing are made to the machine or
  - (d) the machine is damaged by accident or
  - (e) the machine is abused or overloaded or used for a purpose or load beyond its design capabilities, or used in conjunction with a tractor whose power output capability exceeds the stated implement power requirement by more than 40%. For the purpose of these terms and conditions, “stated implement power requirement” refers to wheeled tractors unless specifically stated. These power requirements should be reduced by 20% when used in conjunction with tracked tractors.
  - (f) the machine is operated as part of a ‘cultivation train’ where more than one implement is being towed, without the express written approval of Simba International Ltd.
  - (g) any maintenance is not carried out in accordance with the service schedules in the operator's manual.
  - (h) the Installation and Warranty Registration Certificate is not received by Simba International Ltd., Service Dept., Woodbridge Road, Sleaford, Lincolnshire, England, NG34 7EW, within 7 days of installing a new machine.



# Contents

Machine Identification .....	5
<b>Introduction .....</b>	<b>8</b>
Foreword .....	8
Warranty Guidelines .....	8
<b>1. Safety Data .....</b>	<b>9</b>
1.1 Safety Symbols .....	9
1.2 Use for the Intended Purpose .....	11
1.3 Operational Safety .....	11
1.3.1 No Liability for Consequential Damage .....	11
1.4 Road Traffic Safety .....	12
1.5 Accident Prevention .....	12
1.5.1 Hitching-up the machine .....	12
1.5.2 On the Hydraulic System .....	12
1.5.3 Changing Equipment .....	13
1.5.4 During Operation .....	13
1.6 Servicing & Maintenance .....	13
1.7 Operating Areas .....	14
1.8 Authorised Operators .....	14
1.9 Protective Equipment .....	14
<b>2. Transportation and Installation .....</b>	<b>15</b>
2.1 Delivery .....	15
2.2 Transportation .....	15
2.3 Installation .....	15
2.4 Hitching Up .....	16
2.4.1 Hitching up a Tractor to the CultiPress / Preparing for Transport .....	16
2.5 Folding and Unfolding .....	17
2.5.1 Unfolding into the Work Position .....	17
2.6 Preceding and Trailing Implements .....	18
2.6.1 Hitching a Disc Harrow to the CultiPress .....	18
2.6.2 Transporting an CultiPress Towed Behind a Disc Harrow .....	18
2.6.3 Changing from Work to Road Transport (Disc Harrow Towed Behind a CultiPress). .....	19
2.6.4 Hitching a Rear Roll to the CultiPress .....	19
2.7 When driving on the road .....	20
2.8 Parking the machine .....	20
<b>3. Technical Data CultiPress .....</b>	<b>21</b>
<b>4. Adjustment/Operation .....</b>	<b>22</b>
4.1 Description .....	22
4.2 Pro-Active Tines .....	24
4.3 Levelling Boards .....	24
4.4 Double Disc Roller .....	25
4.5 Work Settings .....	26
4.5.1 Levelling Boards .....	26
4.7 Work Instructions .....	28
4.8 Checks .....	28

<b>5.</b>	<b>Servicing and Maintenance .....</b>	<b>29</b>
5.1	Servicing .....	29
5.2	Cleaning .....	29
5.3	Double Disc Axles .....	29
5.4	Hydraulics .....	29
5.5	Preparation for Storage .....	30
5.6	Operator Support .....	30
5.7	Maintenance Intervals .....	30
5.8	Maintenance Overview .....	31
5.9	Overview of Lubricating Points .....	32
5.10	Lubricating the Machine .....	33
5.11	Handling of Lubricants .....	33
5.12	Lubricants & Hydraulic Oil .....	34
<b>6.</b>	<b>Faults and Remedies .....</b>	<b>35</b>
<b>7.</b>	<b>Parts &amp; Assembly .....</b>	<b>37</b>
7.1	Parts & Assembly Contents .....	37

## Introduction

### Foreword

Make sure you have read and follow the Operating Instructions carefully before using the machine. By doing so, you will avoid accidents, reduce repair costs and downtime and increase the reliability and service life of your machine. Pay attention to the safety instructions!

SIMBA will not accept any responsibility for any damage or malfunctions resulting from failure to comply with the Operating Instructions.

These Operating Instructions will assist you in getting to know your machine and in using it correctly for its intended purposes. First, you are given general instructions in handling the machine. This is followed by sections on servicing, maintenance and the action to be taken should a malfunction occur.

These operating instructions are to be read and followed by all persons working on or with the machine, e.g.:

- Operation (including preparation, remedying of faults in the operating sequence and servicing).
- Maintenance (maintenance and inspection)
- Transportation.

Together with the Operating Instructions, you receive a Spare Parts List and a Machine Registration form. Field service technicians will instruct you in the operation and servicing of your machine. Following this, the Machine Registration form is to be returned to SIMBA. This confirms your formal acceptance of the machine. The warranty period begins on the date of delivery.



We reserve the right to alter illustrations as well as technical data and weights contained in these Operating Instructions for the purpose of improving the CultiPress.

### Warranty Guidelines

1. The period of liability for material defects (warranty) relating to our products is 12 months. In the case of written deviations from the statutory provisions, these agreements shall apply.

They shall become effective upon installation of the machine with the end customer. All wear parts are excluded from the warranty.

2. Warranty claims must be submitted to the SIMBA Customer Service Department in Sleaford via your dealer. It is only possible to process claims which have been correctly completed and submitted no later than 14 days after the date of repair.

3. In the case of deliveries made under the warranty which are subject to the return of the old parts, the old parts must be returned to SIMBA within 28 days after the damage occurred.

4. In the case of deliveries made under the warranty which are not subject to the return of the old parts, these parts must be kept for the purpose of further decisions for a period of 3 months after receipt of the warranty claim.

5. Warranty repairs to be carried out by outside companies, or repairs which are expected to take more than 10 working hours, must be agreed upon in advance with the Customer Service Department.

# 1. Safety Data

The following warnings and safety instructions apply to all sections of these Operating Instructions.

## 1.1 Safety Symbols

### On the machine



Parts may fly off during operation. Keep a safe distance away from the machine!

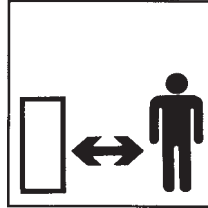

Read and observe the Operating Instructions before starting up the machine!

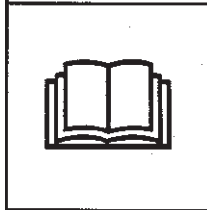

Keep clear of the working range of foldable machine components!



Watch out for escaping pressurised fluids! Follow the instructions in the Operating Instructions!

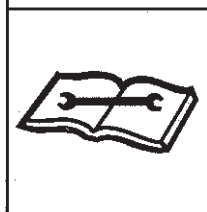

No passengers are allowed on the machine!



Never reach into areas where there is a danger of being crushed by moving parts!

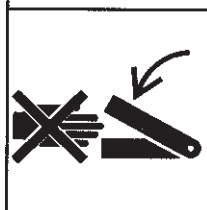

Never reach into any revolving parts!

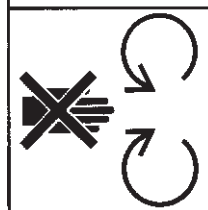



Refer to Operating Instructions before attempting maintenance.

**Operating Instructions:**

The Operating Instructions distinguish between three different types of warning and safety instructions. The following graphic symbols are used:



Important!



Risk of injury!



Risk of fatal and serious injuries!

It is important that all the safety instructions contained in these Operating Instructions and all the warning signs on the machine are read carefully.

Ensure that the warning signs are legible. Replace any signs that are missing or damaged.

These instructions must be followed in order to prevent accidents. Inform other users of the warnings and safety instructions.

Do not carry out any operations which may affect safe use of the machine.

## 1.2 Use for the Intended Purpose

The SIMBA CultiPress is built using the latest technology and in accordance with the relevant recognised safety regulations. However, risks of injury for the operator or third parties and impairment of the machine or other tangible assets can arise during use.

The machine is only to be operated when in a technically perfect condition and for the intended purpose, taking into consideration safety and risks and following the Operating Instructions. In particular, faults that can impair safety are to be remedied immediately.

Original parts and accessories from SIMBA have been specially designed for this machine. Spare parts and accessories not supplied by us have not been tested or authorised. Installation or use of non-original SIMBA products may have a detrimental effect on specific design features of the machine and affect the safety of machine operators and the machine itself. SIMBA will accept no liability for damage resulting from the use of non-original parts or accessories.

The SIMBA CultiPress is designed solely as a cultivation implement. Use for any other purpose, e.g., as a means of transport, will be deemed to be improper use. SIMBA will accept no liability for damage resulting from improper use. The risk will be borne solely by the operator.

## 1.3 Operational Safety

The machine is to be put in operation only after instruction has been provided by an employee of the authorised dealer or an employee of SIMBA. The "Machine Registration" form is to be completed and returned to SIMBA.

All protective and safety equipment, such as removable protective equipment, must be in place and functioning reliably before the machine is put in use.



Check screws and bolts regularly for tightness and retighten if necessary.



In the event of malfunctions, stop and secure the machine immediately.



Ensure that any faults are remedied immediately.

### 1.3.1 No Liability for Consequential Damage

The CultiPress has been manufactured by SIMBA with great care. However, problems may still occur when it is used for the intended purpose. These may include:

- Worn wearing parts.
- Damage caused by external factors.
- Incorrect driving speeds.
- Incorrect setting of the unit (incorrect attachment, non-adherence to the Setting instructions).



Therefore, it is crucial to always check your machine before and during operation for correct operation and adequate application accuracy.

Compensation claims for damage which has not occurred to the machine is excluded. This includes any consequential damage resulting from incorrect operation.

## 1.4 Road Traffic Safety

When driving on public roads, tracks and areas, it is important to observe the relevant road traffic laws as well as the specific regulations relating to this machine.



Pay attention to the permitted axle loads, tyre carrying capacity, and total weight in order to maintain adequate braking and steerability.



Passengers on the machine are strictly forbidden!



Max. road transport speed 16mph (25km/h).

## 1.5 Accident Prevention

In addition to the Operating Instructions, it is important to observe the accident prevention regulations specified by agricultural trade associations.

### 1.5.1 Hitching-up the machine

There is a risk of injury when hitching/unhitching the machine. Observe the following:

- Secure the machine against rolling.
- Take special care when reversing the tractor!
- There is a risk of being crushed between the machine and the tractor!
- Park the machine on firm, level ground.

### 1.5.2 On the Hydraulic System

Do not connect the hydraulic lines to the tractor until both hydraulic systems (machine and tractor) are depressurised.

Only use appropriate aids when checking for leaks. Repair any damage immediately. Spurting oil can cause injuries and fires!

In case of injury, contact a doctor immediately.

The socket and plugs for the hydraulic connections between the tractor and the machine should be colour-coded in order to avoid incorrect use.

### 1.5.3 Changing Equipment

- Secure the machine to prevent it from accidentally rolling away!
- Use suitable supports to secure any raised frame sections suspended above you!
- Caution! Risk of injury due to projecting parts!



Never climb on to rotating parts such as the roll unit. These parts may rotate causing you to slip and suffer serious injury!

### 1.5.4 During Operation

Ensure that the working range and the area around the machine are clear (children!) before operating the machine.

Always ensure adequate visibility!

Do not stand on the machine while it is in operation!

Operators must have a valid driving licence in order to drive on public roads. In the operating area, the operator is responsible for third parties.

The person in charge must:

- provide the operator with a copy of the Operating Instructions.
- ensure that the operator has read and understood the instructions.
- make sure that the operator is aware of the specific regulations relating to the machine when driving on public roads.

## 1.6 Servicing & Maintenance

Ensure that regular checks and inspections are always carried out within the periods required by law or specified in these Operating Instructions.

When carrying out service and maintenance work always:

- switch off the tractor engine and remove the ignition key.
- wait until all the machine parts have stopped moving.
- depressurize the hydraulic system.

Prior to performing maintenance and servicing work, ensure that the machine is positioned on solid, level ground and is secured to prevent it rolling away. Do not use any parts to climb on to the machine unless they are specifically designed for this purpose.

Before cleaning the machine with water, steam jets (high-pressure cleaning apparatus) or other cleaning agents, cover all openings into which, for reasons of safety or operation, no water, steam or cleaning agents are to penetrate (bearings, for instance).

Next, check all hydraulic lines for leaks, loose connections, chafe marks and damage. Remedy any deficiencies immediately!

Lubricate all the lubricating points to force out any trapped water.

When carrying out servicing and maintenance work, retighten any loose screw connections.

## **1.7 Operating Areas**

The operating areas include the drawbar, hydraulic connections and depth adjustment equipment as well as all operating points requiring maintenance.

All operating areas will be specified and described in detail in the following chapters on servicing and maintenance.

Observe all safety regulations included in the Section dealing with Safety, and in the subsequent sections.

## **1.8 Authorised Operators**

Only those persons who have been authorised and instructed by the operator may operate the machine. The operator must be at least 16 years of age.

## **1.9 Protective Equipment**

For operation and maintenance, you require:

- Tight fitting clothing.
- Strong protective gloves (to provide protection against sharp-edged machine components).
- Protective goggles (to stop dirt getting into your eyes).

## 2. Transportation and Installation

Transportation and initial installation of the machine are described in this chapter.

### 2.1 Delivery

The machine is normally delivered fully assembled.

- The machine can be lifted off with a crane or other suitable lifting equipment.
- The machine should be hitched to a tractor and driven off a low-loader.

### 2.2 Transportation

The CultiPress can be transported on public roads by hitching it up to a tractor or on a low-loader.

- It is important to observe the permitted dimensions and weights when transporting the machine.
- If the machine is transported on a trailer or a low-loader, it must be secured using straps or other devices.
- Before transporting the machine on public roads, it must be adjusted to its transportation position and the stipulations relating to road transportation fulfilled.
- The maximum permissible speed is 25 km /h.

### 2.3 Installation

When carrying out installation and maintenance work there is a higher risk of injury. It is important that you familiarise yourself with the machine and read the Operating Instructions beforehand.

Operator instruction and initial installation of the machine are carried out by our service technicians or authorised distributors.

The machine must not be used in any way beforehand! The machine can only be released for operation after instructions have been provided by our service technicians or authorised distributors.

- If any modules or parts have been removed for transportation, these shall be mounted by our service technicians/authorised dealers before the instruction takes place.
- Check all important screw connections!
- Lubricate all nipples and joints!
- Check all hydraulic connections and lines for damage.

## 2.4 Hitching Up

### 2.4.1 Hitching up a Tractor to the CultiPress / Preparing for Transport



When hitching-up the machine, ensure that no-one is between the tractor and the machine.



When the CultiPress is parked for extended periods of time it should ideally be left in the unfolded, i.e. work, position for stability, safety and ease of access for maintenance. However, parking the CultiPress in the folded position (using the parking stands provided) is acceptable in the normal course of operation.



#### **Tractor Oil Flow Adjustment:**

As a general rule the tractor oil flow rate should be set in the lowest setting before starting. This can then be increased to allow the desired rate of operation as applicable. This will minimise excessive oil flow and consequent power usage and heat generation.

#### **Rigid Machines (3.3m and 4.0m):**

1. Couple the four hydraulic hoses to the tractor ensuring that the two levelling board hoses are together and the two drawbar cylinder hoses are together.
2. Connect the tractor to the drawbar using the hydraulics to raise or lower the shackle.
3. Carefully operate the hydraulics to lower the drawbar and tilt the CultiPress onto the road transport wheels. Fully extend the drawbar cylinder.

4. Fully raise the levelling board.
5. Close the tap on the drawbar cylinder.

#### **Folding Machines (4.6m, 5.5m and 6.6m):**

1. Couple the six hydraulic hoses to the tractor ensuring that the two wing hoses are together, the two drawbar cylinder hoses are together and the two levelling board hoses are together.
2. Connect the tractor to the drawbar using the hydraulics to raise or lower the height of the shackle.
3. Carefully operate the hydraulics to lower the drawbar and tilt the CultiPress onto the road transport wheels. Fully extend the drawbar cylinders.
4. This allows the levelling boards to be fully raised so that when the CultiPress is folded the levelling boards do not protrude beyond the 3m transport width. Fully raise the levelling boards.
5. Operate the hydraulics to fold the wings.
6. Ensure that the wing strap is fitted to tie the two wing sections together.
7. Ensure that parking stands are locked in the transport position, ie. fully raised.

## **2.5 Folding and Unfolding**

### **Folding Machines (4.6m, 5.5m and 6.6m)**

#### **2.5.1 Unfolding into the Work Position**

1. Ensure that the parking stands are in the fully raised position.
2. Remove the transport strap from the rear wing cylinders.
3. Open the taps on the hosemast.
4. Operate the hydraulics to fully unfold the wings.
5. Lower the machine to the ground until the chassis is level front to rear or the drawbar cylinders touch the depth stops.

#### **2.5.2 Folding into the Transport Position**

1. Fully raise the levelling boards so that they do not protrude beyond the 3m transport width.
2. Raise the machine onto the transport wheels.
3. Operate the hydraulics to fully fold the wings.
4. Fit the transport strap across the pins on the rear wing cylinders for transport safety.
5. Close the taps on the hosemast.
6. Lower the parking stands if the CultiPress is to be unhitched from the tractor in the folded position.

## 2.6 Preceding & Trailing Implements

### 2.6.1 Hitching a Disc Harrow to the CultiPress

1. Remove the transport straps from the disc harrow, exercise great CARE when extending the axle cylinder.
2. Reverse the disc harrow up to the CultiPress drawbar ensuring that the two drawbars are aligned allowing a slight clearance to enable the machines to be coupled together.
3. Lower the disc harrow to the ground.
4. Connect the four hydraulic hoses from the CultiPress into the disc harrow rear outlets ensuring that the two wing hoses are together and the two drawbar cylinder hoses are together. Ensure that the folding circuits and lift drawbar circuits are coupled correctly.
5. Raise the CultiPress drawbar above the disc drawbar (200mm approx.). Depth control shims may need to be removed.
6. Raise the disc harrow to the same height as the CultiPress drawbar then reverse the disc harrow to couple the two machines together.
7. Fit the drawbar pin.
8. Operate the hydraulics to lower the rear axle and drawbar, tilting the CultiPress onto the road transport wheels. Fully extend the drawbar cylinders.
9. Fully raise the levelling boards.

10. Operate the hydraulics to fold the wings.
11. Operate the hydraulics to lift the disc harrow into the transport position.
12. Fit the disc harrow transport straps.
13. Fit the CultiPress wing transport strap to tie the two wing sections together.
14. Ensure that parking stands are locked up in their work position.

When the CultiPress is used in tandem with a disc harrow the disc should be set to the operators manual i.e. front disc gang to be 50mm closer to the ground than the corresponding disc blade on the rear gang.

With both machines in the transport position i.e. raised and folded, the top frame of the disc harrow should be slightly nose down or horizontal even when the downward load from the CultiPress is applied to the drawbar of the disc harrow.

The frame may be levelled by altering the rearward tilt of the CultiPress to increase or reduce the loading on the disc rear drawbar.

### 2.6.2 Transporting a CultiPress Towed Behind a Disc Harrow

With both machines in the transport position i.e. raised and folded, the top frame of the disc harrow should be slightly nose down or horizontal even when the downward load from the CultiPress is applied to the drawbar of the disc harrow. The top frame should NEVER be tail low in transport as this will give a high negative loading on the tractor which could lead to loss of traction to the rear wheels.

Extreme caution must be taken when the CultiPress is transported up steep gradients

and across side slopes. Higher drawbar loading can be achieved by shortening the drawbar cylinder.

Prior to leaving the field to travel on a public highway ensure that any clods of soil are removed from the machine to prevent them from fouling the road.

MAXIMUM ROAD TRANSPORT SPEED 18 MPH (25 KPH).

### 2.6.3 Changing from Work to Road Transport (CultiPress Towed Behind a Disc Harrow)

1. Operate the hydraulics to raise the disc and CultiPress.
2. Operate the hydraulics to fold the wings on both the disc harrow and the CultiPress.
3. Fit the transport straps to both machines.



It may be necessary to shorten the levelling springs until the top frame of the disc harrow is horizontal or slightly nose down before moving the machines.

Shortening the CultiPress drawbar cylinder will increase the loading on the rear of the disc frame. If necessary this can be used to level the disc top frame for road transport.

### 2.6.4 Hitching a Rear Roll to the CultiPress

Follow procedure 2.4 (page 16) to couple a tractor to the CultiPress. Once the tractor is safely connected to the implement and in its folded setting, raise the machine fully clear of the ground.

1. Reverse the CultiPress up to the roller.
2. Align the CultiPress and roller drawbars, lower the CultiPress to the ground and depressurise the lift hydraulics.
3. Raise / lower the axle as required to align the respective machines' drawbars and couple together.
4. Couple the rear roll to the lift circuit of the CultiPress, ensuring that the hoses are connected to the corresponding circuit on the trailing machine.
5. Couple the rear roll wing (fold) circuit to the wing (fold) circuit of the CultiPress.
6. Fully raise the CultiPress and the roll clear of the ground.
7. Check that all transport straps / devices are fitted or closed.

## 2.7 When driving on the road

When driving on the road the machine must be converted to the transportation position.



When driving on the road, raise the machine completely to prevent the working elements dragging on the ground.

## 2.8 Parking the machine

In order to avoid damage as a result of moisture, the machine should be parked, if possible, indoors or under cover.



When manoeuvring the machine, pay attention to your surroundings. Ensure that nobody is in the manoeuvring area (watch for children!).

- Park the machine on level and solid ground.
- With the machine raised move the parking stands into position.
- Lower the machine onto the parking stands ensuring that it is stable.
- Remove the drawbar pin and drive forward slowly until hitch is clear of tractor drawbar.
- Lower the drawbar to the ground.
- Switch off the tractor.
- Disconnect hydraulic lines from the tractor.

### 3. Technical Data CultiPress

	3.3m	4.0m	4.6m	5.5m	6.6m
<b>Working Width</b>	3300mm	4000mm	4600mm	5500mm	6600mm
<b>Transport Width</b>	3300mm	4000mm	2900mm	2900mm	2900mm
<b>Transport Height</b>	2700mm	2700mm	3600mm	3800mm	3950mm
<b>Length</b>	6400mm	6400mm	6800mm	6800mm	6800mm
<b>Weight</b>	3480kg	3910kg	5660kg	6630kg	7220kg
<b>Tractor Power Required (H.P.)*</b>	85/115	100/140	115/160	140/195	165/230

\* It is important to correctly match your implement to your tractor for optimum performance. Two power ratings are listed above. The lower HP figure relates to tracked tractors, the higher HP figure relates to wheeled tractors.

## 4. Adjustment/Operation

### 4.1 Description

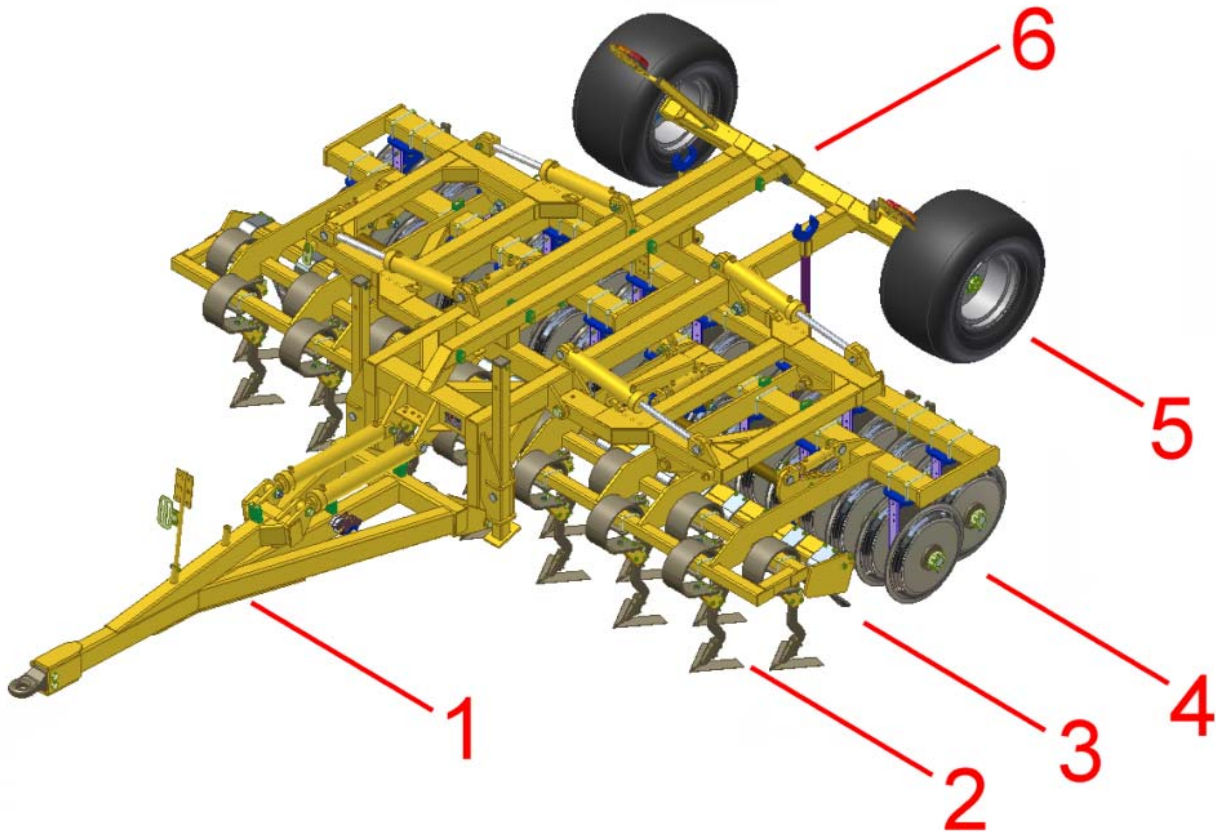

Fig. 4.01: CultiPress

1. Drawbar
2. Pro-Active Tines
3. Levelling Board
4. Intermeshed DD600 Rolls
5. Transport Wheels
6. Rear Drawbar (if fitted)

The SIMBA CultiPress is a versatile implement designed to perform an excellent shallow cultivation combined with effective consolidation. The CultiPress may be towed on its own or in tandem behind another implement e.g. Disc Harrow.

It can be used in reduced tillage systems behind a disc harrow to incorporate stubble or to work down ploughing on medium to

heavy soil types. Like all Simba machines it features the latest innovations which combine to give an efficient, well-built unit with unrivalled reliability.

The CultiPress consists of two rows of tines followed by a hydraulically operated levelling board then a double row of press rings.

Pro-Active tines are spaced at 300mm centres using shear bolt protected tines with point options available to suit conditions.

The levelling board consists of a series of sprung leaves with each leaf set between each front ring. The levelling board carries soil ahead of the rings to fill low areas. The sprung

leaves crush clods as they pass under the levelling board and align clods with the front row of press rings.

The levelling boards are hydraulically controlled for height with contour following and board pressure maintained by means of a pair of accumulators. The hydraulic cylinders on each levelling board are a matched master and slave pair for parallel travel.

The rear row of press roll rings are intermeshed with the front row, overall ring spacing across the machine is thereby reduced to 115mm (4.5"). The action of the second row of rings is to ensure that large clods chopped by the front rings are chopped a second time to reduce overall clod size. The second row of rings are then scraped by a set of rigid scrapers attached to the rear gang beam.

The use of the CultiPress in tandem with a disc harrow for straw incorporation, is to consolidate the straw soil mix through the soil profile ensuring maximum straw soil contact to increase the breakdown process, minimise slug problems and to leave a firm weatherproof finish.

## 4.2 Pro-Active Tines

The Pro-Active tines are designed to move soil and shatter clods to a greater degree than traditional rigid leading tines. The ability to move in all directions (upwards and sideways) allows them to clear stones and other obstructions. They feature simple, pinned tine depth adjustment for easy depth variation.

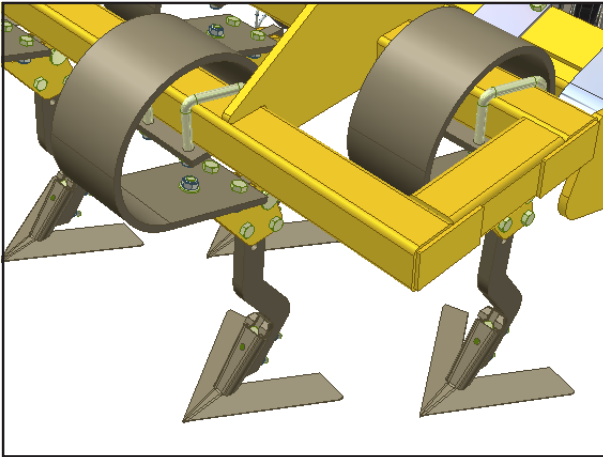

Fig. 4.02: Pro-Active Tines

## 4.3 Levelling Boards

The action of the sprung leaf type levelling boards is to carry and drop soil to level in front of the press rings, to rub clod against clod for additional soil breakdown, to force clods down into the soil profile and to present remaining clods passing between the leaves into the front row of press rings.



Fig. 4.03: Levelling Board Adjustment



Fig. 4.04: Levelling Board Adjustment

## 4.4 Double Disc Roller

The standard DD600 roller is made up of individual Double Disc (patented) Ring segments.

The DD rings are designed to consolidate the soil whilst cutting and crushing any clods.

Even in heavy, wet soils it can easily be operated with minimal blockages occurring.

The rear DD roller carries a proportion of the machine's weight to ensure consolidation. The corrugated surface left by the roller is weatherproof both for wet or dry situations.



*Fig. 4.05: Double Disc Rollers*

## 4.5 Work Settings

In work the wing cylinders should be fully extended. The gangs are able to float over any undulations on the ground due to their floating frames.

Optimum performance has been found to be achieved when the press roll rings have worn away the painted finish leaving a smooth shiny surface. When the press roll rings are new or rusty, soil may tend to pick up on the surface and blockage may occur, this will reduce when the rings are shiny again.

The CultiPress should be run with the chassis level front to rear by extending the drawbar cylinders to the necessary position. The cylinders should not be over extended as this will remove the load on the front row of rings which could lead to reduced drive and hence blockage of the axles.

It is not necessary to tilt the CultiPress onto the transport wheels during headland turns whether the machine is used independently or in tandem with a disc harrow. Normally, the CultiPress should be tilted sufficiently for the tines and levelling boards to clear the ground (at which point the rear axle wheels will still be clear of ground contact).

### 4.5.1 Levelling Boards

With the chassis set level, lower the levelling boards until they are carrying soil. The levelling boards will need to be set higher during 1st pass operations especially on ploughed land where large clods may not be able to pass under or between the sprung leaves.

The boards need to carry a certain amount of soil to effect a levelling operation and also to give a clod to clod crushing action. Use the hydraulics to raise and lower the boards to carry more or less soil when levelling the headland troughs for example.

When reversing the CultiPress into corners when working headlands ensure that the levelling boards are fully raised and the machine tilted onto the rear set of rings far enough to allow the lower ends of the sprung leaves to clear the ground.

#### General Rules when Setting the CultiPress

- Run the chassis horizontal to give even drive on both sets of rings.
- Run slightly tail low to give increased clod cutting and consolidation in harder conditions.
- In trashy conditions the use of the levelling board may be limited due to raking trash.
- Increase the rake angle of the levelling board in spring time operation to carry more soil for levelling.
- Reduce rake angle on levelling board to hold soil and rub clod against clod in harder conditions. This will also align clods with the DD rings facilitating better cutting.

## 4.6 Pitch Control

Pitch control on the CultiPress is governed by the quantity of shims fitted to the depth stops attached to the drawbar cylinders. Increasing the number of shims will lift the front of the chassis when lowered into the work position. Ensure that equal quantities of shims are added or removed from each cylinder.

Running the CultiPress level allows the front and rear press rings to give an even consolidation and clod crushing action, with the sprung leaves of the levelling board aiding the clod crushing action, aligning the clods for the front row of rings.

Running the machine significantly nose down or raised will reduce the load on the rear axle leading to loss of drive of the axle and then blockage, together with a reduced consolidation effect.

If any roll axle starts to block regularly, this is generally an indication that the roll axle is not tight. Failure to keep the axles tight results in loss of drive between each pair of rings allowing rings to turn individually on the axle. Should this occur the axle must be tightened immediately to prevent any damage occurring to the axle shaft.

If the roll axles start to block regularly this may also be an indication that the ground conditions are too wet for the CultiPress to be effective.

In practice it is possible to use the CultiPress on ground conditions that are unsuitable to achieve the desired effect, and it is usually possible to operate the machine without regular blockage under such unsuitable conditions, assuming that the axles are tight and rings smooth.

As such, especially under wet conditions, it

is advisable to check on the cultivation effect of the CultiPress. Often the use of the press 12 - 24 hours after the disc or longer following the plough gives a far superior surface consolidation effect.

When the CultiPress is used tilted onto the rear row of rings the loading on the disc harrow or tractor drawbar is increased. This will cause the rear of the disc to dig deeper moving the rear gang to the right. Shortening the disc harrow levelling springs should allow the disc harrow to pull straight again. Equally, increased tractor drawbar loadings will deepen wheelings requiring more effort to eradicate these.

It is not necessary to tilt the CultiPress onto the transport wheels during headland turns whether the machine is used independently or in tandem with a disc harrow.



Fully extending the drawbar cylinders and then reversing into the headland furrow could lead to damage of the cylinders.

## 4.7 Work Instructions

### Driving speed

The CultiPress can be driven at speeds of up to 12 km/h.

This depends on the field conditions (type of soil, surface trash, etc.).

Drive more slowly if the conditions are difficult or a firmer finish is required.

### Parking the Machine

In order to avoid damage as a result of moisture, the machine should be parked, if possible, indoors or under cover.



When manoeuvring the machine, pay attention to your surroundings. Ensure that nobody (children!) is in the manoeuvring area.

- Park the machine on level and solid ground.
- With the machine raised, lower the parking stands into position.
- Lower the machine onto the parking stands ensuring that it is stable.
- Remove the drawbar pin and drive forward slowly until hitch is clear of tractor drawbar.
- Lower the drawbar to the ground.
- Switch off the tractor.
- Disconnect hydraulic and electric lines from the tractor.

## 4.8 Checks

The working quality depends on the adjustments and checks made prior to and during work, as well as on regular servicing and maintenance of the machine.

Before beginning work it is therefore important to carry out any necessary servicing and to lubricate the machine as required.

### Checks prior to, and during work:

- Is the machine correctly hitched up and the coupling device locked?
- Have the hydraulic and electric lines been connected according to the colour coding?
- Is the machine in a level operating position and the working depth set correctly?

### Working Elements

- Are the double disc rings and other cultivation tools in a serviceable condition?
- Are the scrapers still operable, so that the rolls do not jam?

## 5. Servicing and Maintenance



Follow the safety instructions for servicing and maintenance.

### 5.1 Servicing

Your machine has been designed and constructed for maximum performance, operational efficiency and operator friendliness under a wide variety of operating conditions.

Prior to delivery, your machine has been checked at the factory and by your authorised dealer to ensure that you receive a machine in optimum condition.



To ensure trouble-free operation, it is important that servicing and maintenance work is performed at the recommended intervals.

### 5.2 Cleaning

In order to ensure that the machine is always in operating condition and to achieve optimum performance, perform the cleaning and servicing work at regular intervals.

Avoid cleaning the roll / disc bearings with a high- pressure hose or a direct water jet. The housing, screwed connections and ball bearings are not watertight.

### 5.3 Double Disc Axles

The axles on this roller are tensioned by the main axle through the centre of the rings and bearings.



Specialist equipment is required for the disassembly of Double Disc axles. Please consult your dealer under any circumstances that require disassembly of these axles.

Maintenance of these rollers is limited to daily greasing of the bearings to flush out dirt, and regular inspection to ensure the assemblies are tight, and scrapers are correctly set. The axles can be tightened provided the bearing pillar 'U' bolts are loosened to avoid preloading the bearings as they move sideways to each other. Ensure the bearing pillars are re-tightened to the mainframe after this.

### 5.4 Hydraulics



A low oil flow should be used, i.e., tractor tickover or low flow selected.



The wing circuit is controlled by an overcentre valve contained within the manifold block which positively locks oil flow until pressurised by the tractor. System pressure can be retained in the circuit **even after depressurisation** of the tractor quick release couplings.



Exercise extreme care when checking the valve or circuits, and *under no circumstances* attempt to adjust or loosen fittings without prior reference to your authorised Simba dealer, and detailed maintenance instructions.

## 5.5 Preparation for Storage

If you need to store the machine for a longer period, observe the following points:

- Park the machine undercover if possible.
- Protect the roll / discs against rust. If you need to spray the implements with oil, use light biologically degradable oils, e.g. rape oil.



Cover any rubber sections before using oil sprays. These sections must not be oiled.

Remove any traces of oil with a suitable cleaning agent.

## 5.6 Operator Support

If you have a problem, please contact your dealer. They will endeavour to solve any problems which may occur and provide you with support at all times.

In order to enable your dealer to deal with problems as quickly as possible, it helps if you can provide them with the following data. Always state the:

- Customer Number
- Name and Address
- Machine Model
- Serial Number of Machine
- Date of Purchase and Operating Hours
- Type of Problem

## 5.7 Maintenance Intervals

Apart from daily maintenance, the maintenance intervals are based on the number of operating hours and time data.

Keep a record of your operating hours to ensure that the specified maintenance intervals are adhered to as closely as possible.

Never use a machine that is due for maintenance. Ensure that all deficiencies found during regular checks are remedied immediately.



Avoid sharp-edged and pointed parts (disc blades, etc.) when working on the machine.



Place the machine on suitable supports when working underneath! Do not work under a machine which is not supported!

## 5.8 Maintenance Overview

CultiPress Maintenance Overview			
	Instructions	Interval	Note
<b>After first operation</b>			
Check all screw, bolt and plug connections	Check they are firmly seated. Tighten / Secure if necessary	---	---
Check wheel studs for tightness	Check on delivery and before transporting the machine	---	---
Lubricate machine	See overview of lubricating points	---	Page 32
<b>During operation</b>			
Lubricate machine	See overview of lubricating points	---	Page 32
Wheel studs	Check tightness before transporting the machine	daily	---
Levelling Board, Machine Pitch, Working Depth	Check settings and ensure they are firmly secured	daily	Page 26, 27
Hydraulic system and components	Check seals, signs of crushing/wear, function and condition	daily	Page 29
Roll bearings	Check condition, mountings and smooth operation	daily	Pages 25, 29
Double Disc roller ring segments	Check condition and ensure they are firmly secured	daily	Pages 25, 29
Safety devices (Parking stands, transport strap)	Check condition and function	daily	---
<b>After season</b>			
Lubricate machine	See overview of lubricating points	---	Page 32
Toplinks / Bolts	Grease any exposed threads	---	---
Entire machine	Carry out cleaning and maintenance	---	---
Spray Double Disc roll with oil	Use biological oil if possible - cover rubber elements	---	---
<b>After 4 years</b>			
Hydraulic pipes	Replace	MRL Anh I	EN 1533

## 5.9 Overview of Lubricating Points

CultiPress Lubrication Points	Interval	Diag. No.
DD Roll Bearings	Daily	5.01
Pivot Points on Drawbar	50 hrs.	5.02
Pivot Points on Wings (folding machines only)	50 hrs.	5.03
Levelling Board Cylinder Pivots	50 hrs.	5.04
Wheel Bearings	50 hrs.	5.05

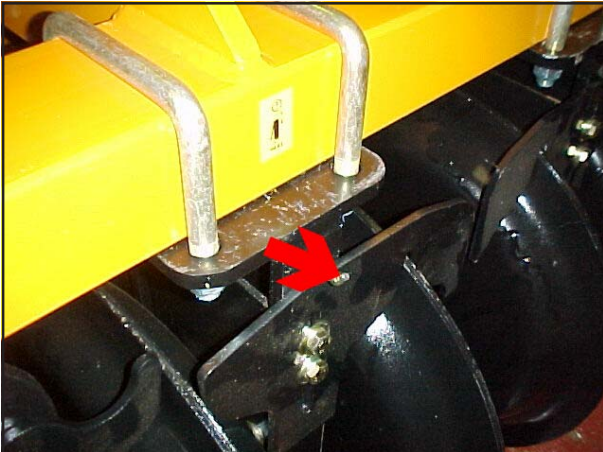

Fig. 5.01: DD Roll Grease Points

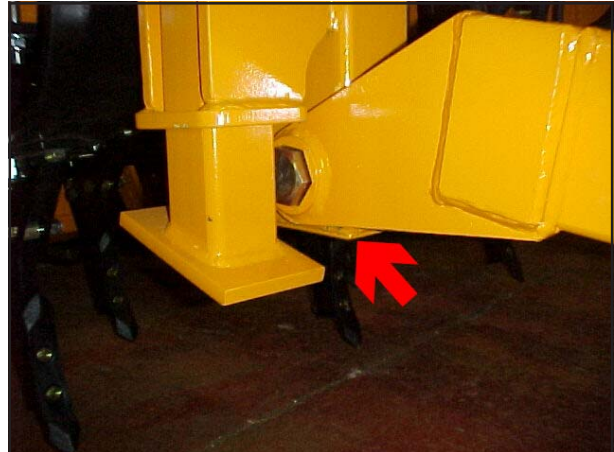

Fig. 5.02: Drawbar Pivot Grease Points



Fig. 5.03: Wing Pivot Grease Points

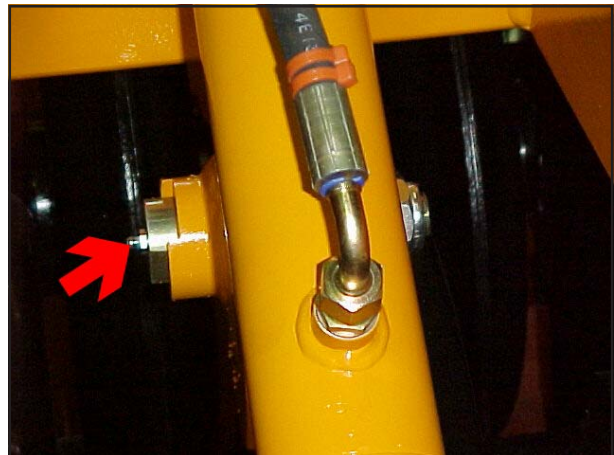

Fig. 5.04: Levelling board Grease Points



Fig. 5.05: Wheel Bearing Grease Points

## 5.10 Lubricating the Machine

Please read the section entitled "Using Lubricants" carefully before lubricating the machine.

The machine must be lubricated regularly in order for it to remain serviceable. Regular lubrication also contributes towards extending the service life of your machine.

The recommended lubricating intervals are specified in "Inspection" and "Maintenance Intervals".

After it has been washed using a high-pressure hose or steam cleaned, the machine should always be lubricated using a grease gun.

## 5.11 Handling of Lubricants

Please ensure that you read the following instructions as well as the relevant information. This also applies to any of your employees who handle lubricants.

### Hygiene

Lubricants do not present a health hazard provided they are used for their specified purpose.

In the case of prolonged skin contact, lubricants - especially low-viscosity oils - may remove the natural layer of fat contained in the skin, resulting in dryness and possible irritation.

It is important to take extreme care when handling waste oil as it may contain other irritants.

Vapours given off by cleaning agents and oils are also a potential health hazard.

You should therefore not carry any oily cloths around. Change soiled work clothing as soon as possible.

Always exercise extreme care and observe the recommended hygiene rules when handling mineral oil products. Details of these handling regulations can be found in information provided by the health authorities.

### Storage and Handling

- Always store lubricants where they cannot be accessed by children.
- Never store lubricants in open or unlabelled containers.

### Fresh Oil

- Apart from taking the usual care and observing hygiene rules, there is no need to take any special precautions when handling fresh oil.

### Waste Oil

- Waste oil can contain harmful contaminants which may cause skin cancer, allergies and other illnesses.

### Attention!

Oil is a toxic substance. Should you swallow any oil, do not try to vomit. Contact a doctor immediately.

Protect your hands with barrier cream or wear gloves to avoid contact with the skin. Wash off any traces of oil thoroughly with soap and hot water.

- Wash your skin thoroughly with soap and water.
- Use special cleaning agents to clean any dirt off your hands.
- Never wash oil residue from your skin with petrol, diesel fuel or paraffin.
- Avoid skin contact with any oily clothing.
- Do not keep any oily rags in your pockets.
- Wash soiled clothing before wearing it again.
- Ensure that any oily footwear is disposed of in the proper manner.

## Measures in case of injury through oil

### Eyes:

Should any oil be splashed into your eyes, rinse with water for 15 minutes. If the eye is still irritated, contact a doctor immediately

### If oil is swallowed

If oil is swallowed, it is important not to induce vomiting. Contact a doctor immediately.

### Skin irritation caused by oil

In case of prolonged skin contact, wash off the oil with soap and water.

### Oil Spills

Use either sand or a suitable granular absorbent to soak up any spilt oil. Dispose of the oil-contaminated absorbent in the proper manner.

### Oil Fires

Never use water to extinguish an oil fire. The oil will float on the water causing the fire to spread.

Burning oil-lubricant must be extinguished using a carbon dioxide powder or foam extinguisher. Always wear respiratory equipment when dealing with fires of this type.

## Waste Oil Disposal

Oil-contaminated waste and used oil must be disposed of in accordance with current legislation.

Waste oil must be collected and disposed of in accordance with local regulations. Never pour used oil into unsealed sewage systems or drains or onto the ground.

## 5.12 Lubricants & Hydraulic Oil

### Hydraulic System

The hydraulic fluid from the tractor is mixed with the hydraulic fluid from the machine.

The supplied machine hydraulic system contains Total AZOLLA ZS 32 oil.

### Lubricants

All lubricating points on the machine can be lubricated with multigrade lubricating grease as specified in DIN 51825 KP/2K - 40.

## 6. Faults and Remedies

CultiPress Troubleshooting		
Fault	Possible cause	Remedy
Front roll axle starts to block regularly.	Machine running too tail low.	Shorten work drawbar cylinder until main frame is horizontal or just tail low.
		Reduce quantity of shims in depth stop unit.
	Front to rear ring tracking out of alignment.	Reset ring centres to run rear rings centrally between the front rings.
	Roll axle is not tight.	Tighten axle.
	Ground conditions too wet.	Wait for more suitable conditions.
Rear roll axle starts to block regularly.	Machine running too tail high.	Lengthen work drawbar cylinder until main frame is horizontal or just tail low.
		Increase quantity of shims in depth stop unit.
	Roll axle is not tight.	Tighten axle.
	Ground conditions too wet	Wait for more suitable conditions
	Front to rear ring tracking out of alignment	Reset ring centres to run rear rings centrally between the front rings
	Rear roll scrapers incorrectly adjusted.	Set scrapers to run just clear of rings and centrally between each ring.
Levelling boards drop at headland turns.	Tractor spool valve in float position.	Operate levelling boards using pressure only.
Levelling boards become unphased.	Tractor spool valve in float position.	Operate levelling boards using pressure only.

---

**Space for Notes:**