

The logo for the Series 5 Toolbar features a central white rectangular box with a black border containing the text "SERIES 5 TOOLBAR" in a bold, red, serif font. This box is flanked by four orange, slanted rectangular bars that create a sense of motion or a stylized 'S' shape.

**SERIES 5  
TOOLBAR**

P14222 20/01/06





**DECLARATION OF CONFORMITY**

Simba International Limited hereby declare that the Product described in this Operators Manual, and defined by the 5 digit Registration number stamped onto the inside of the roller, conforms with the following Directives and Regulations, and has been certified accordingly.

**EC Machinery Directive 89/392/EEC, as amended by 91/3688/EEC, 93/44/EEC, and 93/688/EEC.**

In order to fulfill the requirements of health and safety described in the EC Directive, the following standards and technical specifications have been taken into account:

**EN 292 - 1**  
**EN 292 - 2**

**THE MANUFACTURER**

Simba International Limited  
Woodbridge Road  
SLEAFORD  
NG34 7EW  
Lincolnshire  
NG34 7EW  
England.

Telephone 01529 304654.

**CERTIFIED ON BEHALF OF SIMBA INTERNATIONAL LIMITED.**

Philip J. Wright. BSc (Hons) C Eng. MI Agr.E  
Technical Director.



## **WARRANTY** **TERMS AND CONDITIONS**

In this warranty Simba International Ltd., is referred to as “the Company”.

1. Subject to the provisions of this warranty the Company warrants each new machine sold by it to be sold free from any defect in material or workmanship for a period of 12 months from date of installation with the end-user.

Some specific items have additional warranty over and above the standard 12 months. Details of these can be obtained upon request directly from the distributor or Simba International Ltd.

2. If the machine or part thereof supplied by the Company is not in accordance with the warranty given in clause 1 the Company will at its option:

- (a) make good the machine or part thereof at the Company's expense, or
- (b) make an allowance to the purchaser against the purchase price of the machine or part thereof, or
- (c) accept the return of the machine and at the buyers option either:
  - I) repay or allow the buyer the invoice price of the machine or part thereof, or
  - II) replace the machine or part thereof as is reasonably practical.

3. This warranty shall not oblige the Company to make any payment in respect of loss of profit or other consequential loss or contingent liability of the Purchaser alleged to arise from any defect in the machine or impose any liability on the Company other than that contained in clause 2.

4. Any claim under this warranty must be notified to the Company in writing specifying the matters complained of within 14 days from the date of repair.

5. Any claim under this warranty must be made by the original purchaser of the machine and is not assignable to any third party.

6. If the purchaser hires out the machine to any third party the warranty shall apply only to matters notified to the Company in writing within 90 days of the date of delivery and clause 1 shall be read as if the period of 90 days were substituted for the period of 12 months.

7. The warranty will cease to apply if:

- (a) any parts not made, supplied or approved in writing by the Company are fitted to the machine or
- (b) any repair is carried out to the machine other than by or with the express written approval of the Company or
- (c) any alterations not expressly authorized by the Company in writing are made to the machine or
- (d) the machine is damaged by accident or
- (e) the machine is abused or overloaded or used for a purpose or load beyond its design capabilities, or used in conjunction with a tractor whose power output capability exceeds the stated implement power requirement by more than 40%. For the purpose of these terms and conditions, “stated implement power requirement” refers to wheeled tractors unless specifically stated. These power requirements should be reduced by 20% when used in conjunction with tracked tractors.
- (f) the machine is operated as part of a ‘cultivation train’ where more than one implement is being towed, without the express written approval of Simba International Ltd.
- (g) any maintenance is not carried out in accordance with the service schedules in the operator's manual.
- (h) the Installation and Warranty Registration Certificate is not received by Simba International Ltd., Service Dept., Woodbridge Road, Sleaford, Lincolnshire, England, NG34 7EW, within 7 days of installing a new machine.

## Machine Identification

Enter the relevant data in the following list upon acceptance of the machine:

Serial Number	
Type of Machine	
Machine Width	
Year of Construction	
Delivery Date	
First Operation	
Accessories	

Operating Instructions/Spare Parts List: January 2006

Dealer Address:      Name: .....  
                          Street: .....  
                          Place: .....  
                          Tel.: .....

Dealer's Customer No.: .....

SIMBA Address:      SIMBA  
                          Woodbridge Road Ind. Est.  
                          Sleaford  
                          Lincolnshire  
                          NG34 7EW

Tel.:            01529 304654  
 Fax:            01529 413468  
 E-Mail:        simba.international@simba.co.uk

SIMBA Customer No.: .....



# Contents

Machine Identification .....	5
<b>Introduction .....</b>	<b>8</b>
Foreword .....	8
Warranty Guidelines .....	8
<b>1. Safety Data .....</b>	<b>9</b>
1.2 Use for the Intended Purpose .....	9
1.3 Operational Safety .....	10
1.4 No Liability for Consequential Damage .....	10
1.5 Changing Equipment .....	10
1.6 During Operation .....	10
1.7 Servicing & Maintenance .....	10
<b>2. Transportation and Installation .....</b>	<b>11</b>
2.1 Delivery .....	11
2.2 Transportation .....	11
2.3 Installation .....	11
2.4 Hitching-up the machine .....	11
2.5 When driving on the road .....	12
2.6 Parking the machine .....	12
<b>3. Adjustment/Operation .....</b>	<b>13</b>
3.1 Description .....	13
3.1.1 Mainframe .....	13
3.1.2 Trailing Kit .....	14
3.1.3 Tines .....	15
3.2 Work Instructions .....	15
3.3 Checks .....	15
3.4 Parking .....	15
3.5 Settings .....	16
<b>4. Servicing and Maintenance .....</b>	<b>17</b>
4.1 Servicing .....	17
4.2 Cleaning .....	17
4.3 Storage / Parking .....	17
4.4 Operator Support .....	17
4.5 Maintenance Intervals .....	17
4.6 Maintenance Overview .....	18
4.7 Overview of Lubricating Points .....	19
4.8 Lubricating the Machine .....	19
4.8.1 Handling of Lubricants .....	19
4.8.2 Hygiene .....	19
4.8.3 Storage and Handling .....	20
4.8.4 Measures in case of injury through oil .....	20
4.8.5 Oil Spills .....	20
4.8.6 Oil Fires .....	20
4.8.7 Waste Oil Disposal .....	20
4.9 Lubricants & Hydraulic Oil .....	20
4.9.1 Hydraulic System .....	20
4.9.2 Lubricants .....	20
<b>5. Parts &amp; Assembly .....</b>	<b>21</b>

## Introduction

### Foreword

Make sure you have read and follow the Operating Instructions carefully before using the machine. By doing so, you will avoid accidents, reduce repair costs and downtime and increase the reliability and service life of your machine. Pay attention to the safety instructions!

SIMBA will not accept any responsibility for any damage or malfunctions resulting from failure to comply with the Operating Instructions.

These Operating Instructions will assist you in getting to know your component and in using it correctly for its intended purposes. First, you are given general instructions in handling the component. This is followed by sections on servicing, maintenance and the action to be taken should a malfunction occur.

These operating instructions are to be read and followed by all persons working on or with the component, e.g.:

- Operation (including preparation, remedying of faults in the operating sequence and servicing).
- Maintenance (maintenance and inspection)
- Transportation.

Together with the Operating Instructions, you receive a Spare Parts List and a Machine Registration form. Field service technicians will instruct you in the operation and servicing of your machine. Following this, the Machine Registration form is to be returned to SIMBA. This confirms your formal acceptance of the machine. The warranty period begins on the date of delivery.



We reserve the right to alter illustrations as well as technical data and weights contained in these Operating Instructions for the purpose of improving the component.

### Warranty Guidelines

1. The period of liability for material defects (warranty) relating to our products is 12 months. In the case of written deviations from the statutory provisions, these agreements shall apply.

They shall become effective upon installation of the machine with the end customer. All wear parts are excluded from the warranty.

2. Warranty claims must be submitted to the SIMBA Customer Service Department in Sleaford via your dealer. It is only possible to process claims which have been correctly completed and submitted no later than 14 days after the date of repair.

3. In the case of deliveries made under the warranty which are subject to the return of the old parts, the old parts must be returned to SIMBA within 28 days after the damage occurred.

4. In the case of deliveries made under the warranty which are not subject to the return of the old parts, these parts must be kept for the purpose of further decisions for a period of 3 months after receipt of the warranty claim.

5. Warranty repairs to be carried out by outside companies, or repairs which are expected to take more than 10 working hours, must be agreed upon in advance with the Customer Service Department.

# 1. Safety Data

The following warnings and safety instructions apply to all sections of these Operating Instructions. All safety instructions for the machine should be followed.

## 1.1 Operating Instructions:

The Operating Instructions distinguish between three different types of warning and safety instructions. The following graphic symbols are used:



Important!



Risk of injury!



Risk of fatal and serious injuries!

It is important that all the safety instructions contained in these Operating Instructions and all the warning signs on the machine are read carefully.

Ensure that the warning signs are legible. Replace any signs that are missing or damaged.

These instructions must be followed in order to prevent accidents. Inform other users of the warnings and safety instructions.

Do not carry out any operations which may affect safe use of the machine.

## 1.2 Use for the Intended Purpose

The SIMBA Series 5 Toolbar is built using the latest technology and in accordance with the relevant recognised safety regulations. However, risks of injury for the operator or third parties and impairment of the machine or other tangible assets can arise during use.

The Toolbar unit is only to be operated when in a technically perfect condition and for the intended purpose, taking into consideration safety and risks and following the Operating Instructions. In particular, faults that can impair safety are to be remedied immediately.

Original parts and accessories from SIMBA have been specially designed for this unit. Spare parts and accessories not supplied by us have not been tested or authorised. Installation or use of non-original SIMBA products may have a detrimental effect on specific design features of the unit and affect the safety of machine operators. SIMBA will accept no liability for damage resulting from the use of non-original parts or accessories.

The SIMBA Series 5 Toolbar is designed solely as a Toolbar unit. Use for any other purpose, e.g., as a means of transport, will be deemed to be improper use. SIMBA will accept no liability for damage resulting from improper use. The risk will be borne solely by the operator.

### 1.3 Operational Safety

All protective and safety equipment, such as removable protective equipment, must be in place and functioning reliably before the machine is put in use.



Check screws and bolts regularly for tightness and retighten if necessary.



In the event of malfunctions, stop and secure the machine immediately.



Ensure that any faults are remedied immediately.

### 1.4 No Liability for Consequential Damage

The Series 5 Toolbar has been manufactured by SIMBA with great care. However, problems may still occur when it is used for the intended purpose. This may include:

- Worn wearing parts.
- Damage caused by external factors.
- Incorrect driving speeds.
- Incorrect setting of the unit (incorrect attachment, non-adherence to the Setting instructions).



Therefore, it is crucial to always check your Toolbar unit before and during operation for correct operation and adequate application accuracy.

Compensation claims for damage which has not occurred to the component is excluded. This includes any consequential damage resulting from incorrect operation.

### 1.5 Changing Equipment

- Use suitable supports to secure any raised frame sections suspended above you!
- Caution! Risk of injury due to projecting parts!

### 1.6 During Operation

The person in charge must:

- provide the operator with a copy of the Operating Instructions.
- ensure that the operator has read and understood the instructions.

### 1.7 Servicing & Maintenance

Ensure that regular checks and inspections are always carried out within the periods required by law or specified in these Operating Instructions.

Prior to performing maintenance and servicing work, ensure that the machine is positioned on solid, level ground and is secure and stable.

Before cleaning the unit with water, steam jets (high-pressure cleaning apparatus) or other cleaning agents, cover all openings into which, for reasons of safety or operation, no water, steam or cleaning agents are to penetrate.

When carrying out servicing and maintenance work, retighten any loose screw connections.

## 2. Transportation and Installation

Transportation and initial installation of the machine are described in this chapter.

### 2.1 Delivery

The Toolbar unit is normally delivered, fully assembled, on a (low-bed) truck.

The machine can be lifted off with a crane, fork-lift truck, or other suitable lifting equipment.

When doing so, the weight, the centre of gravity and the attachment points on the unit are to be taken into account.

Depending on the lifting gear, attachment is only to be at appropriate points on the frame.

### 2.2 Transportation

The Series 5 Toolbar can be transported on public roads by hitching it up to a tractor or on a low-bed truck.

The Series 5 Toolbar unit must be lifted clear of the ground for road transport when transported behind a tractor.

- It is important to observe the permitted dimensions and weights when transporting the machine.
- Use suitable lifting gear, e.g. a fork-lift truck.
- If the machine is transported on a trailer or a flat-bed truck, it must be secured using straps or other devices.
- Before transporting the machine on public roads, it must be adjusted to its transportation position and the stipulations relating to road transportation fulfilled.
- The maximum permissible speed is 25 km /h.

### 2.3 Installation

When carrying out installation and maintenance work there is a higher risk of injury. It is important that you familiarise yourself with the component and read the Operating Instructions beforehand.

### 2.4 Hitching-up the machine



When hitching-up the machine, ensure that no-one is between the tractor and the machine.

- Couple the machine to the tractor.
- Hook up the hydraulics.



Connect the hydraulic system only when the hydraulic couplings are depressurised.

## 2.5 When driving on the road

When driving on the road the machine must be converted to the transportation position.



There is a risk of injury on specially sharpened edges and when making adjustments on the machine.



When driving on the road, raise the machine completely to prevent the working elements dragging on the ground. Ensure the transport locks are fitted to the hydraulic cylinders in road transport.

The maximum permissible road transport speed is 25 km /h.

## 2.6 Parking the machine

In order to avoid damage as a result of moisture, the machine should be parked, if possible, indoors or under cover.



When manoeuvring the machine, pay attention to your surroundings. Ensure that nobody is in the manoeuvring area (watch for children!).

- Park the machine on level and solid ground.
- Lower the machine so that it is supported.
- Disconnect hydraulic lines from the tractor.
- Unhitch the machine.

## 3. Adjustment/Operation

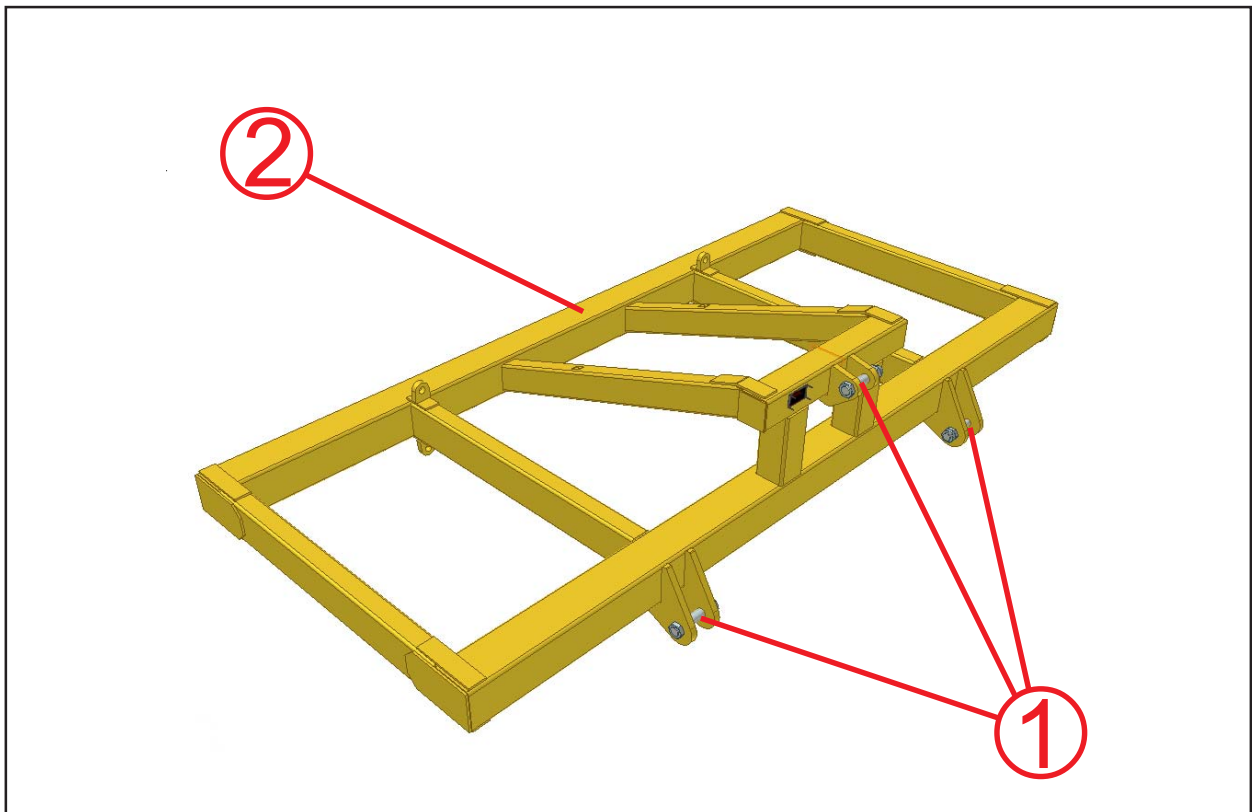

Fig. 3.01: Series 5 Toolbar Frame

### 3.1 Description

#### 3.1.1 Mainframe

1. Attachment points for trailing unit
2. Mainframe

The SIMBA Series 5 Toolbar is designed for deep soil loosening. This promotes good root development by providing a non-compacted soil profile.

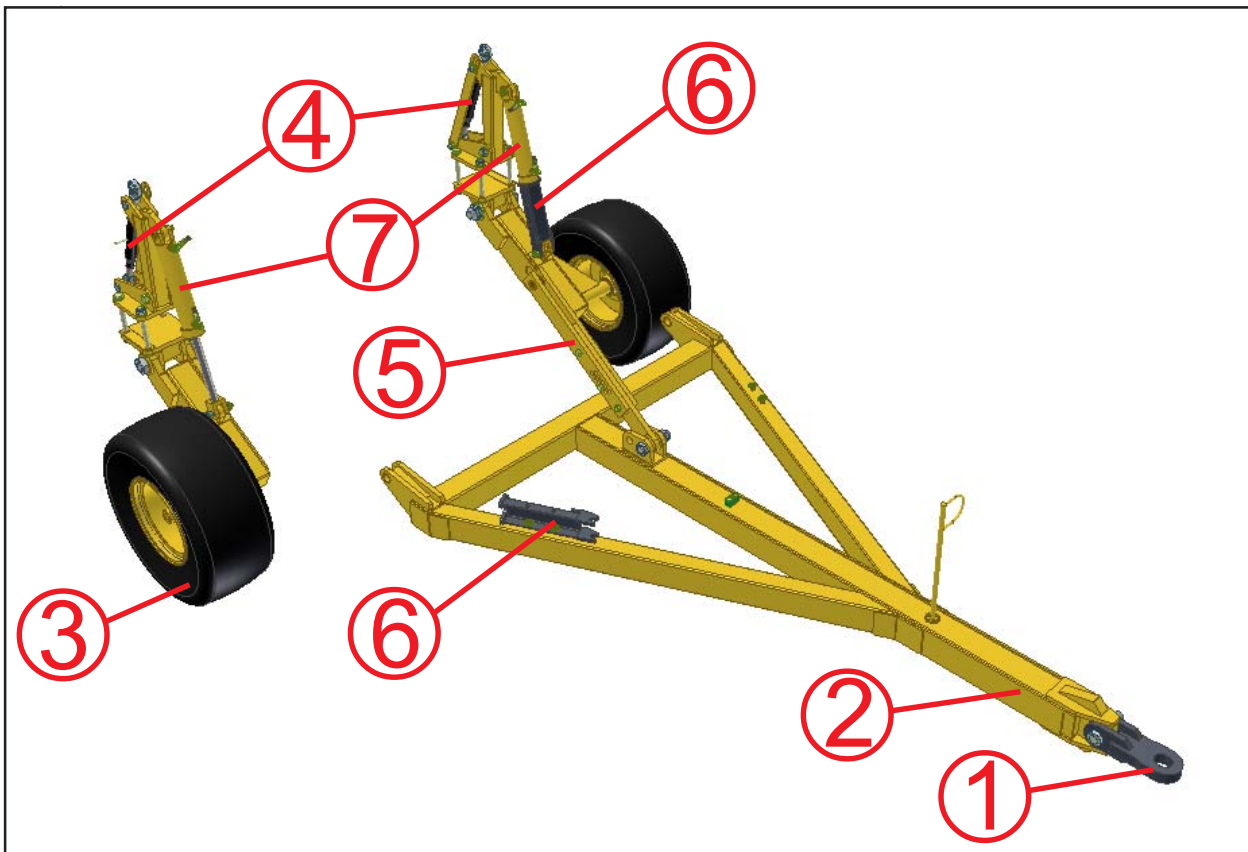

Fig. 3.02: Series 5 Toolbar Trailing Kit

### 3.1.2 Trailing Kit

1. Hitch
2. Drawbar
3. Transport Wheels
4. Toplinks (wheel adjustment)
5. Drawbar Adjuster (pitch adjustment)
6. Transport Locks
7. Hydraulic Cylinders

The wheel units are used both for depth control and for road transport. When in road transport the machine is lifted clear of the ground using a hydraulic cylinder on each wheel unit.

For depth control in work, each wheel is set via topline adjusters to the required working depth. When in work the hydraulic cylinder on each wheel is used in the fully closed position.

### 3.1.3 Tines

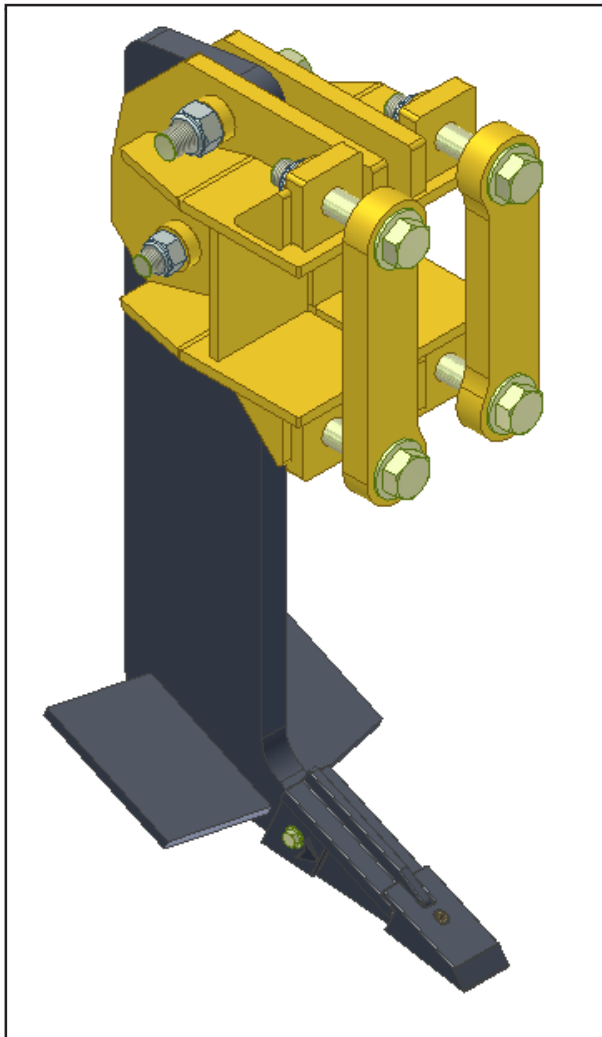

Fig. 3.03: Series 5 Toolbar Tines

The subsoiler tines are manufactured from 40mm thick high tensile steel to reduce bending in adverse conditions. The tine units are also shear bolt protected to minimise the risk of damage to the legs and frame. The tines feature 2 part pinned-on tips and replacable wings.

### 3.2 Work Instructions

Turning:



Before turning, the machine should be eased out of work while driving. Likewise, it should be eased back into work once the turn has been completed.

In work the Series 5 Toolbar can be driven at speeds between 8-12km/h.

### 3.3 Checks

The working quality depends on the adjustments and checks made prior to and during work, as well as on regular servicing and maintenance of the component.

Before beginning work it is therefore important to carry out any necessary servicing required.

#### Working Elements

- Are the working elements in good working order?

### 3.4 Parking

In order to avoid damage as a result of moisture, the machine should be parked, if possible, indoors or under cover.



When manoeuvring the machine, pay attention to your surroundings. Ensure that nobody is in the manoeuvring area (watch for children!).

- Park the machine on level and solid ground.
- Lower the machine so that it is supported.
- Disconnect hydraulic lines from the tractor.
- Unhitch the machine.

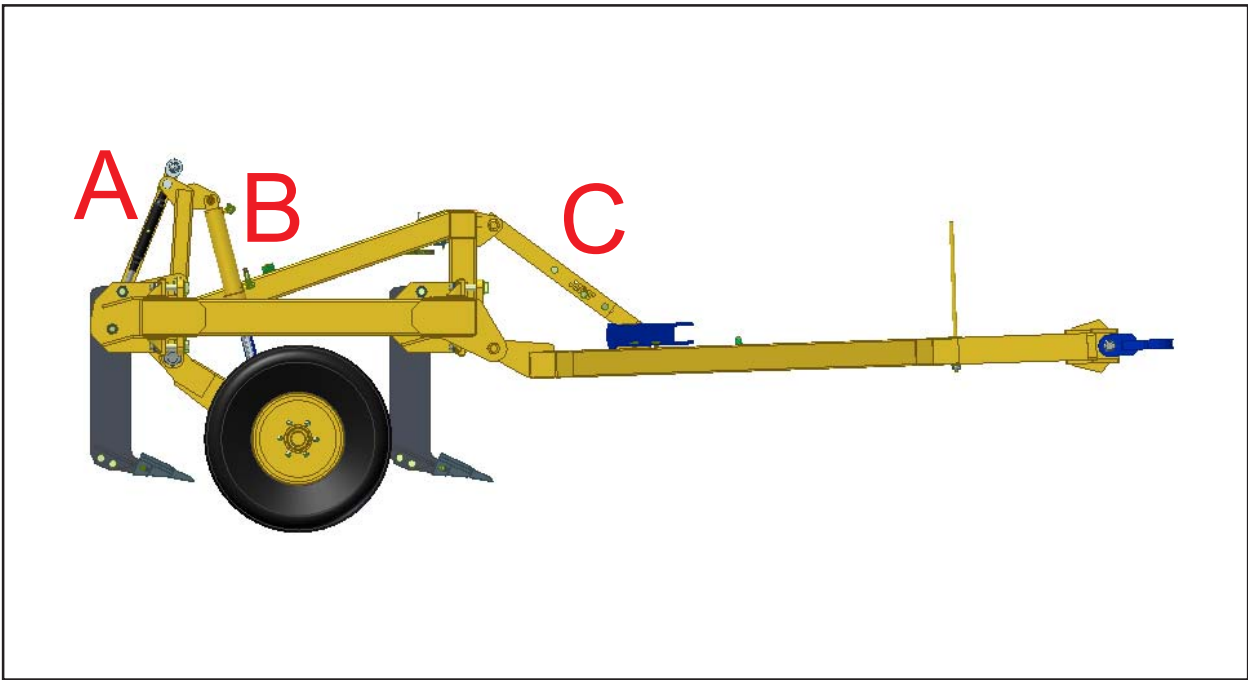

Fig. 3.04: Series 5 Toolbar Settings

### 3.5 Settings

The drawbar may be attached to the tractor rigid drawbar or the pick up hitch. Altering the length of the drawbar adjuster (C) will raise or lower the back of the frame to alter the draught requirements and quality of work. The drawbar adjuster may also be used to take account of varying tractor drawbar heights.

Alteration of working depth is effected by altering the length of the top link on each wheel unit (A). Both wheel units must be set to exactly the same length. Remember to check the wheels for clearance after any adjustment. The tie bars should NEVER be removed, therefore should reduced depth still be required when working at the limit of the tie bars; the tines will need to be raised in their clamps.

To adjust working depth proceed as follows: -

Raise the machine and drive forward onto hard ground. Lower the machine fully to eliminate pressure in the hydraulic system.

Retain the hydraulic lever in the 'lower' or 'float' position, then lengthen the adjusters to decrease depth or shorten to increase depth as required.

When entering work ensure that the transport locking units are removed, then lower the tines to the ground, draw forwards until the correct operating depth is achieved. In work the hydraulic cylinders (B) should be in the fully closed position. To leave work, extend the hydraulic cylinders so that the tines are clear of the ground.

## 4. Servicing and Maintenance



Follow the safety instructions for servicing and maintenance.

### 4.1 Servicing

Your Series 5 Toolbar unit has been designed and constructed for maximum performance, operational efficiency and operator friendliness under a wide variety of operating conditions.

Prior to delivery, your Toolbar unit has been checked at the factory and by your authorised dealer to ensure that you receive it in optimum condition.

To ensure trouble-free operation, it is important that servicing and maintenance work is performed at the recommended intervals.



When changing points on tines extreme care should be taken. Wear goggles at all times when changing tine points.

### 4.2 Cleaning

In order to ensure that the Toolbar is always in operating condition and to achieve optimum performance, perform the cleaning and servicing work at regular intervals.

### 4.3 Storage / Parking

In order to avoid damage as a result of moisture, the machine should be parked, if possible, indoors or under cover.

### 4.4 Operator Support

If you have a problem, please contact Your dealer. They will endeavour to solve any problems which may occur and provide you with support at all times.

In order to enable your dealer to deal with problems as quickly as possible, it helps if you can provide them with the following data. Always state the:

- Customer Number
- Name and Address
- Machine Model
- Serial Number
- Date of Purchase and Operating Hours
- Type of Problem

### 4.5 Maintenance Intervals

Apart from daily maintenance, the maintenance intervals are based on the number of operating hours and time data.



Keep a record of your operating hours to ensure that the specified maintenance intervals are adhered to as closely as possible.



Never use a Series 5 Toolbar unit that is due for maintenance. Ensure that all deficiencies found during regular checks are remedied immediately.



Place the machine on suitable supports when working underneath! Do not work under a machine which is not supported!

On a new machine tighten all nuts and bolts after 5 hours work and again after 15 hours. This also applies to parts that have been moved or replaced. After the initial 15 hours of work a once a week check should be sufficient depending on daily work rates.

## 4.6 Maintenance Overview

Series 5 Toolbar Maintenance Overview			
	Instructions	Interval	Note
<b>After first operation</b>			
Check all screw, bolt and plug connections	Check they are firmly seated. Tighten / Secure if necessary - Refer to table below for bolt torques	---	---
Check wheel studs for tightness	Check on delivery and before transporting the machine	---	---
Lubricate machine	See overview of lubricating points	---	Page 19
<b>During operation</b>			
Lubricate machine	See overview of lubricating points	---	Page 19
Toplinks / Drawbar adjuster	Check setting and ensure they are firmly secured	daily	Page 16
Hydraulic system and components	Check seals, signs of crushing/wear, function and condition	daily	---
Tines, points and wings.	Check condition, mountings and settings	daily	Page 15
Safety devices (transport locks)	Check condition and function	daily	---
<b>After season</b>			
Lubricate machine	See overview of lubricating points	---	Page 19
Toplinks / Bolts	Grease any exposed threads	---	---
Entire machine	Carry out cleaning and maintenance	---	---
<b>After 4 years</b>			
Hydraulic pipes	Replace	MRL Anh I	EN 1533

Max. Bolt Torques	
M12 8.8	10 KgM ( 73 lb.ft)
M16 8.8	24 KgM ( 176 lb.ft)
M20 8.8	47 KgM ( 345 lb.ft)
M24 8.8	80 KgM ( 587 lb.ft)
M30 8.8	150 KgM ( 1100 lb.ft)
M36 8.8	280 KgM ( 2055 lb.ft)
5/8" UNC	24 KgM ( 175 lb.ft)

## 4.7 Overview of Lubricating Points

Series 5 Toolbar lubrication points	Interval	Diag. No.
Trailing Unit Wheel Pivot and Pivot Bolt	50 Hours	4.01
Trailing Unit Wheel Bearings	50 Hours	4.02

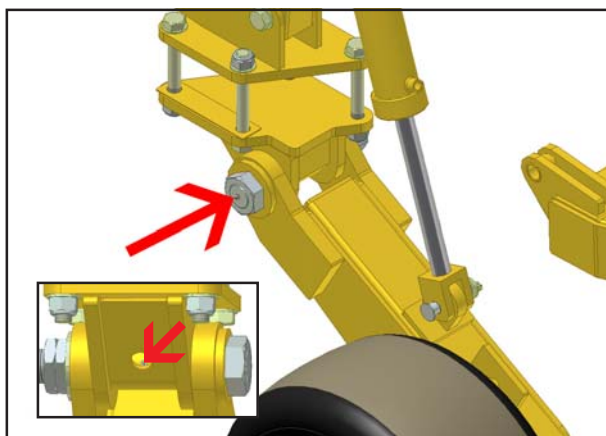

Fig. 4.01: Wheel Pivot Grease Points

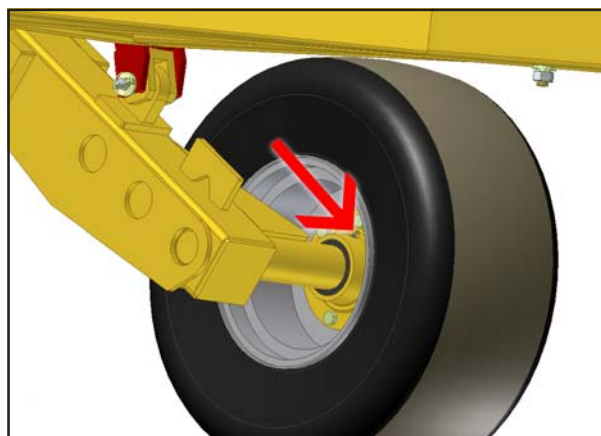

Fig. 4.02: Wheel Hub Grease Points

## 4.8 Lubricating the Machine

Please read the section entitled "Using Lubricants" carefully before lubricating the machine.

The machine must be lubricated regularly in order for it to remain serviceable. Regular lubrication also contributes towards extending the service life of your machine.

The recommended lubricating intervals are specified in "Inspection" and "Maintenance Intervals".

After it has been washed using a high-pressure hose or steam cleaned, the machine should always be lubricated using a grease gun. Ensure that the universal joints and splined shafts are lubricated regularly.

### 4.8.1 Handling of Lubricants

Please ensure that you read the following instructions as well as the relevant information. This also applies to any of your employees who handle lubricants.

### 4.8.2 Hygiene

Lubricants do not present a health hazard provided they are used for their specified purpose.

In the case of prolonged skin contact, lubricants - especially low-viscosity oils - may remove the natural layer of fat contained in the skin, resulting in dryness and possible irritation.

It is important to take extreme care when handling waste oil as it may contain other irritants.

Vapours given off by cleaning agents and oils are also a potential health hazard.

You should therefore not carry any oily cloths around. Change soiled work clothing as soon as possible.

Always exercise extreme care and observe the recommended hygiene rules when handling mineral oil products. Details of these handling regulations can be found in information provided by the health authorities.

### 4.8.3 Storage and Handling

- Always store lubricants where they cannot be accessed by children.
- Never store lubricants in open or unlabelled containers.

#### Fresh Oil:

- Apart from taking the usual care and observing hygiene rules, there is no need to take any special precautions when handling fresh oil.

#### Waste Oil:

- Waste oil can contain harmful contaminants which may cause skin cancer, allergies and other illnesses.

#### Attention!

Oil is a toxic substance. Should you swallow any oil, do not try to vomit. Contact a doctor immediately.

Protect your hands with barrier cream or wear gloves to avoid contact with the skin. Wash off any traces of oil thoroughly with soap and hot water.

- Wash your skin thoroughly with soap and water.
- Use special cleaning agents to clean any dirt off your hands.
- Never wash oil residue from your skin with petrol, diesel fuel or paraffin.
- Avoid skin contact with any oily clothing.
- Do not keep any oily rags in your pockets.
- Wash soiled clothing before wearing it again.
- Ensure that any oily footwear is disposed of in the proper manner.

### 4.8.4 Measures in case of injury through oil

#### Eyes:

Should any oil be splashed into your eyes, rinse with water for 15 minutes. If the eye is still irritated, contact a doctor immediately

#### If oil is swallowed:

If oil is swallowed, it is important not to induce vomiting. Contact a doctor immediately.

#### Skin irritation caused by oil:

In case of prolonged skin contact, wash off the oil with soap and water.

### 4.8.5 Oil Spills

Use either sand or a suitable granular absorbent to soak up any spilt oil. Dispose of the oil-contaminated absorbent in the proper manner.

### 4.8.6 Oil Fires

Never use water to extinguish an oil fire. The oil will float on the water causing the fire to spread.

Burning oil-lubricant must be extinguished using a carbon dioxide powder or foam extinguisher. Always wear respiratory equipment when dealing with fires of this type.

### 4.8.7 Waste Oil Disposal

Oil-contaminated waste and used oil must be disposed of in accordance with current legislation.

Waste oil must be collected and disposed of in accordance with local regulations. Never pour used oil into unsealed sewage systems or drains or onto the ground.

## 4.9 Lubricants & Hydraulic Oil

### 4.9.1 Hydraulic System

The hydraulic fluid from the tractor is mixed with the hydraulic fluid from the machine.

The supplied machine hydraulic system contains Total AZOLLA ZS 32 oil.

### 4.9.2 Lubricants

The lubricating points on the machine can be lubricated with multigrade lubricating grease as specified in DIN 51825 KP/2K - 40.

## 5. Parts & Assembly

### Table of contents

Series 5 Toolbar Complete .....	22
Trailing Kit Assembly .....	24
Mainframe .....	26
Tine Assembly .....	28
Hydraulic Components .....	62
Hydraulic Circuit .....	64

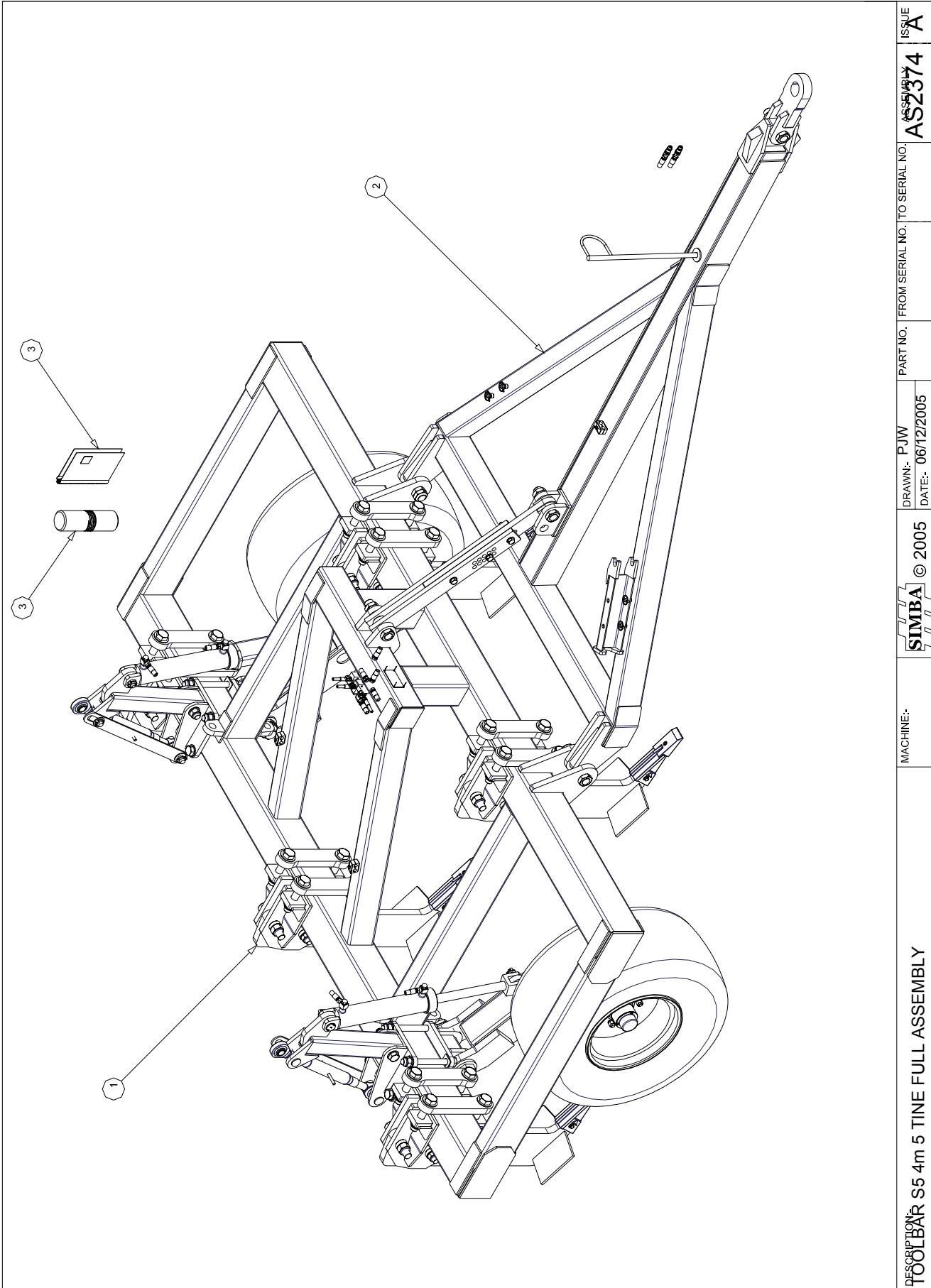

DESCRIPTION: <b>TOOLBAR S5 4m 5 TINE FULL ASSEMBLY</b>	MACHINE:-	© 2005	DRAWN: PJW DATE: 06/12/2005	PART NO. FROM SERIAL NO. TO SERIAL NO.	ASSEMBLY NO. <b>AS2374</b>	ISSUE <b>A</b>
---	-----------	--------	--------------------------------	--	----------------------------	----------------

AS2374		TOOLBAR S5 4m 5 TINE ASSEMBLY		
ITEM	PART NO	DESCRIPTION	QTY	COMMENTS
1	AS2373	TOOLBAR - S4/5 TINE AND CLAMP ASSEMBLY	5	
2	AS2375	TRAILING KIT ASSEMBLY	1	
3	AS2383	TOOLBAR S4/5 MAIN FRAME ASSEMBLY	1	
4				
5				
6				
7				
8				
9				
10				
11				
12				
13				
14				
15				
16				
17				
18				
19				
20				
21				
22				
23				
24				
25				
26				
27				
28				
29				
30				
31				
32				
33				
34				
35				
36				
37				
38				
39				
40				
41				
42				
43				
44				
45				
46				
47				
48				
49				
50				

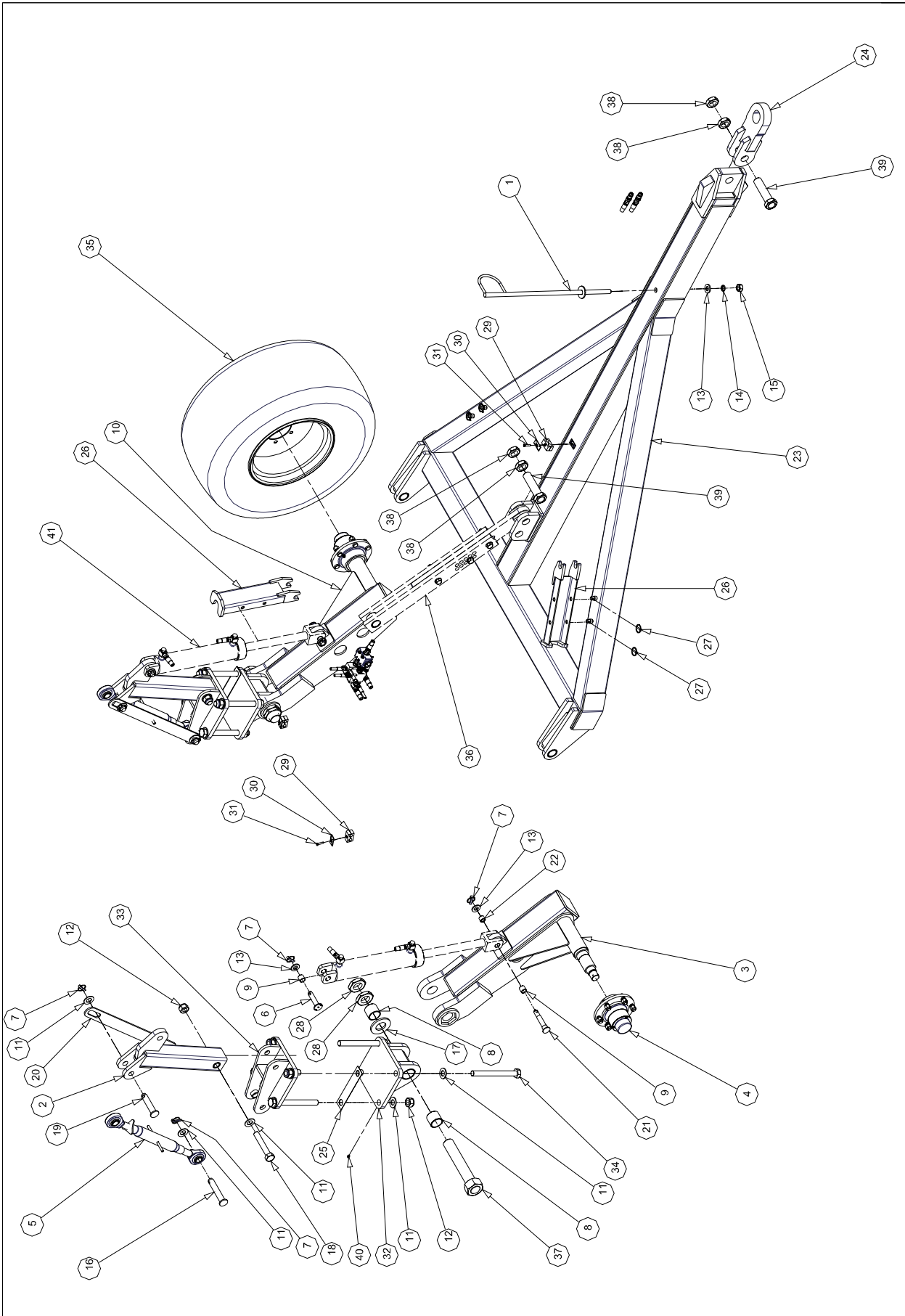

DESCRIPTION:	TRAILING KIT ASSEMBLY	MACHINE- FLATLINER	© 2005	DRAWN: ARH DATE: 12/04/2004	PART NO. FROM SERIAL NO. TO SERIAL NO.	ASSEMBLY AS2375	ISSUE A
--------------	-----------------------	-----------------------	--------	--------------------------------	--	--------------------	------------

AS2375		TRAILING KIT ASSEMBLY			
ITEM	PART NO	DESCRIPTION	QTY	COMMENTS	
1	P00305	HOSE MAST - 150RHS	1		
2	P00871	ADJUSTER POST	2		
3	P03503	WHEEL LEG RH	1		
4	P00641	6 STUD HUB ASSEMBLY	2		
5	P00159	TOPLINK CAT 3 19"	2		
6	P01274	PIN Ø25x115	3		
7	P02484	LYNCH PIN CAT 2	8		
8	P02890	BUSH SPRUNG - Ø72xØ62x60	4		
9	P01645	BUSH SPRUNG - Ø32xØ26x32	4		
10	P03502	WHEEL LEG LH	1		
11	P02608	WASHER FLAT M30	24		
12	P02011	NUT LOCK M30	10		
13	P02604	WASHER FLAT M24 Ø50	13		
14	P02593	WASHER SPRING M24	1		
15	P00717	NUT PLAIN M24	1		
16	P10857	PIN Ø31.75x180	2		
17	P04010	WASHER FLAT M60x10	2		
18	P00036	BOLT M30x180 GR. 8.8	2		
19	P00538	PIN Ø31.75x150	2		
20	P02503	TIE BAR	2		
21	P01148	TRANSPORT PIN Ø25x127	2		
22	P01149	BUSH Ø30xØ24x23	2		
23	P03495	DRAWBAR S5 TRAILING KIT	1		
24	P02480	SHACKLE TYPE I	1	Ø46, Ø68x9 SLOT	
25	P04342	CAMBER PLATE 3mm	2		
26	P01564	TRANSPORT LOCK 100x400	2		
27	P02483	LYNCH PIN CAT 1	4		
28	P01697	NUT PLAIN M60 HALF	4	HALF NUT	
29	P09112	CLAMP ½" BSP PAIR	3		
30	P09113	CLAMP - TOP PLATE	3		
31	P10096	BOLT M8x35 GR. 8.8	3		
32	P00801	LOWER AXLE PIVOT	2		
33	P00802	UPPER AXLE PIVOT	2		
34	P06672	BOLT M30x300 GR. 10.9	8	35mm THREAD	
35	P03958	WHEEL ASSY 18X19.5 6 STUD	2		
36	AS2392	TOPLINK - SIMBA FAB	1	P01562	
37	P01871	BOLT M60x330	2		
38	P13344	1/2 NUT PLAIN M45x3	4		
39	P14220	BOLT M45x175	2	SUPERCEDES P00383	
40	P12891	NIPPLE - GREASE M10	2		
41	AS2393	HYDRAULIC COMPONENT LAYOUT	1		
42					
43					
44					
45					
46					
47					
48					
49					
50					



AS2383		TOOLBAR S4/5 MAIN FRAME ASSEMBLY		
ITEM	PART NO	DESCRIPTION	QTY	COMMENTS
1	P03494	TOOLBAR S5 4m	1	
2	P13344	1/2 NUT PLAIN M45x3	6	
3	P14221	BOLT M45x220	3	SUPERCEDES P00051
4	P05122	SERIAL PLATE	1	
5	P13092	RIVET Ø3x10x Ø6 HEAD	4	
6	P13013	MANUAL CASE Ø100	1	
7	P14222	MK4 TOOLBAR - OPERATORS MANUAL	1	
8				
9				
10				
11				
12				
13				
14				
15				
16				
17				
18				
19				
20				
21				
22				
23				
24				
25				
26				
27				
28				
29				
30				
31				
32				
33				
34				
35				
36				
37				
38				
39				
40				
41				
42				
43				
44				
45				
46				
47				
48				
49				
50				

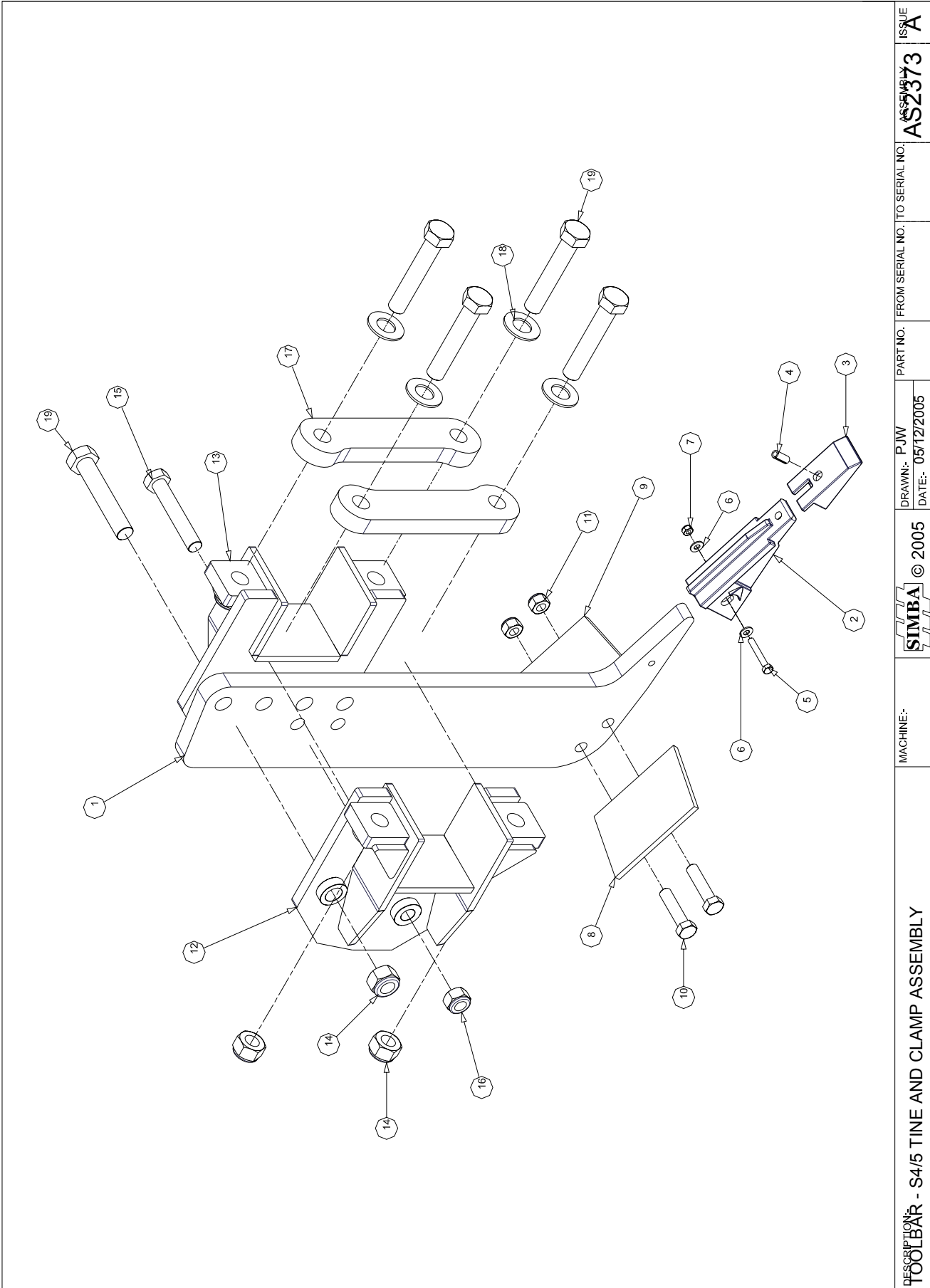

DESCRIPTION: <b>TOOLBAR - S4/5 TINE AND CLAMP ASSEMBLY</b>	MACHINE:-	SIMBA © 2005	DRAWN:- PJW DATE:- 05/12/2005	PART NO. FROM SERIAL NO. TO SERIAL NO.	ASSEMBLY NO.	ISSUE
		ASSEMBLY NO.	ASSEMBLY NO.	ASSEMBLY NO.	ASSEMBLY NO.	ASSEMBLY NO.

AS2373		TOOLBAR - S4/5 TINE AND CLAMP ASSEMBLY		
ITEM	PART NO	DESCRIPTION	QTY	COMMENTS
1	P05737	TINE STRAIGHT 40mm	1	200AR200D
2	P02016	POINT BODY - S4/5	1	
3	P02017	TIP - S4 CAST	1	
4	P02481	ROLL PIN Ø16x40	1	
5	P00006	BOLT M12x80 GR. 8.8	1	
6	P02601	WASHER FLAT M12	2	
7	P02007	NUT LOCK M12	1	
8	P14241	WING RH S4 150mm	1	
9	P14240	WING LH S4 150mm	1	
10	P00017	BOLT M24x100 GR. 8.8	2	
11	P02010	NUT LOCK M24	2	
12	P14239	TINE CLAMP RH S5	1	
13	P14238	TINE CLAMP LH S5	1	
14	P02012	NUT LOCK M36	5	
15	P00036	BOLT M30x180 GR. 8.8	1	
16	P02011	NUT LOCK M30	1	
17	P02772	PLATE - RTG S5	2	
18	P02609	M36 FLAT WASHER	4	
19	P00045	BOLT M36x200 GR. 8.8	5	
20				
21				
22				
23				
24				
25				
26				
27				
28				
29				
30				
31				
32				
33				
34				
35				
36				
37				
38				
39				
40				
41				
42				
43				
44				
45				
46				
47				
48				
49				
50				

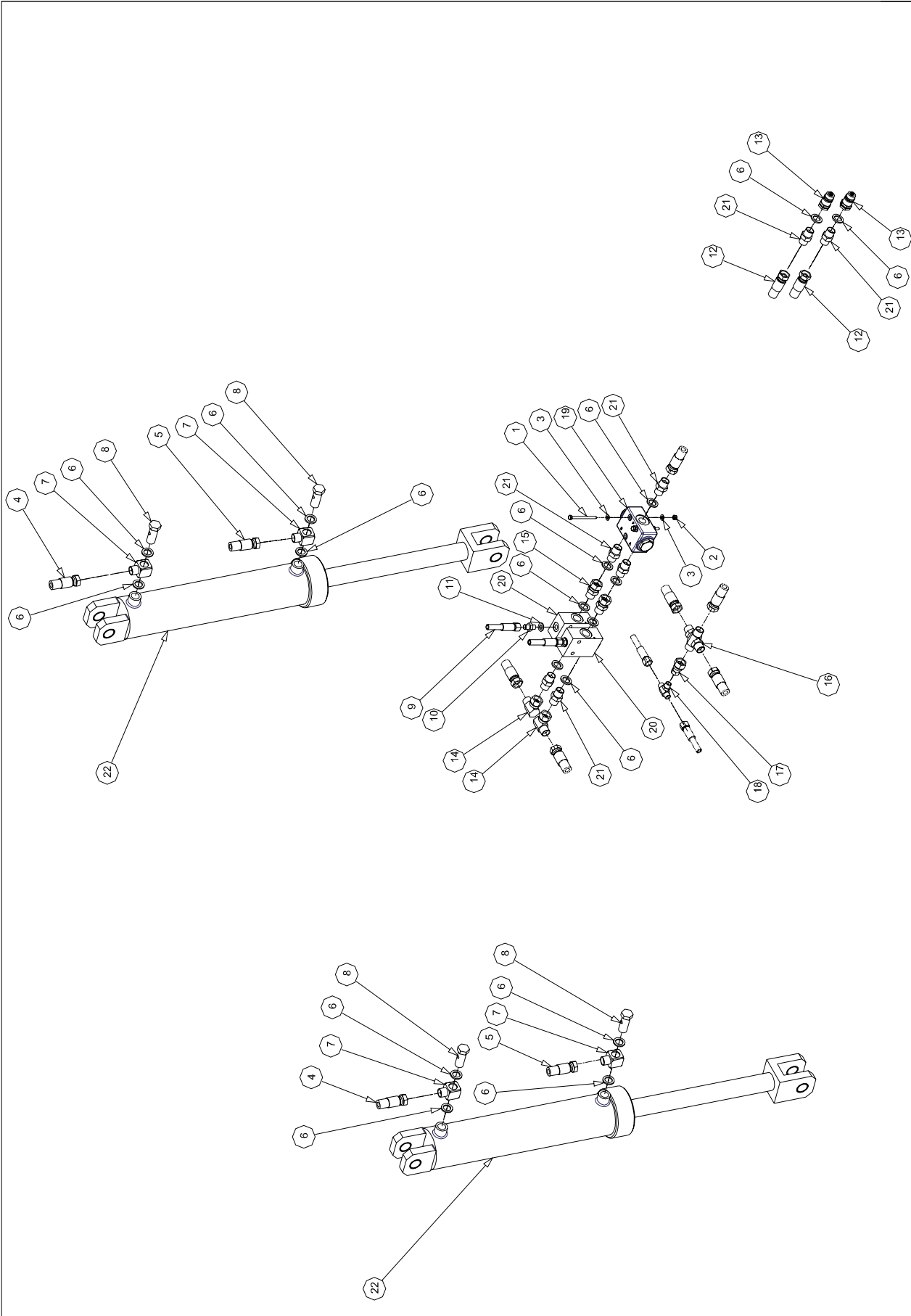

DESCRIPTION: <b>HYDRAULIC COMPONENT LAYOUT</b>	MACHINE:- S5 TOOLBAR	© 2005	DRAWN: PJG DATE: 16/12/2005	PART NO. FROM SERIAL NO. TO SERIAL NO. <b>AS2393</b>	ISSUE <b>A</b>
---	-------------------------	--------	--------------------------------	---	-------------------

AS2393		TOOLBAR SERIES 5 - HYDRAULIC COMPONENTS		
ITEM	PART NO	DESCRIPTION	QTY	COMMENTS
1	P05399	BOLT M6x75 GR. 8.8	2	
2	P07981	NUT LOCK M6	2	
3	P05400	WASHER FLAT M6	4	
4	P07952	HA 1/2"x3660	2	
5	P00184	HA 1/2"x3660	2	
6	P02263	DOWTY SEAL 1/2" BSP	17	
7	P00200	BANJO BLOCK 1/2" BSP	4	
8	P00201	BANJO BOLT 1/2" BSP	4	
9	P12010	HA 1/4"x300 90°	2	
10	P02881	ADAPTOR MALE-MALE 1/4" BSP	2	
11	P02741	DOWTY SEAL 1/4" BSP	2	
12	P00191	HA 1/2"x3660	2	
13	P00205	QUICKRELEASE MALE - 1/2" BSP	2	
14	P02734	ELBOW MALE-FEM COMPACT 1/2" BSP	2	
15	P00206	ADAPTOR MALE-FEM 1/2" BSP	2	
16	P00209	ADAPTOR 4 WAY 1/2" BSP	1	
17	P02882	ADAPTOR FEM 1/2" - FEM 1/4" BSP	1	
18	P02742	ADAPTOR T 1/4" BSP	1	
19	P00872	FDC - 1/2" BSP	1	
20	P02883	PILOT CHECK VALVE	2	
21	P00203	ADAPTOR MALE-MALE 1/2" BSP	7	
22	P00164	CYLINDER - Ø3¾"x400 - 45	2	673-1073
23				
24				
25				
26				
27				
28				
29				
30				
31				
32				
33				
34				
35				
36				
37				
38				
39				
40				
41				
42				
43				
44				
45				
46				
47				
48				
49				
50				

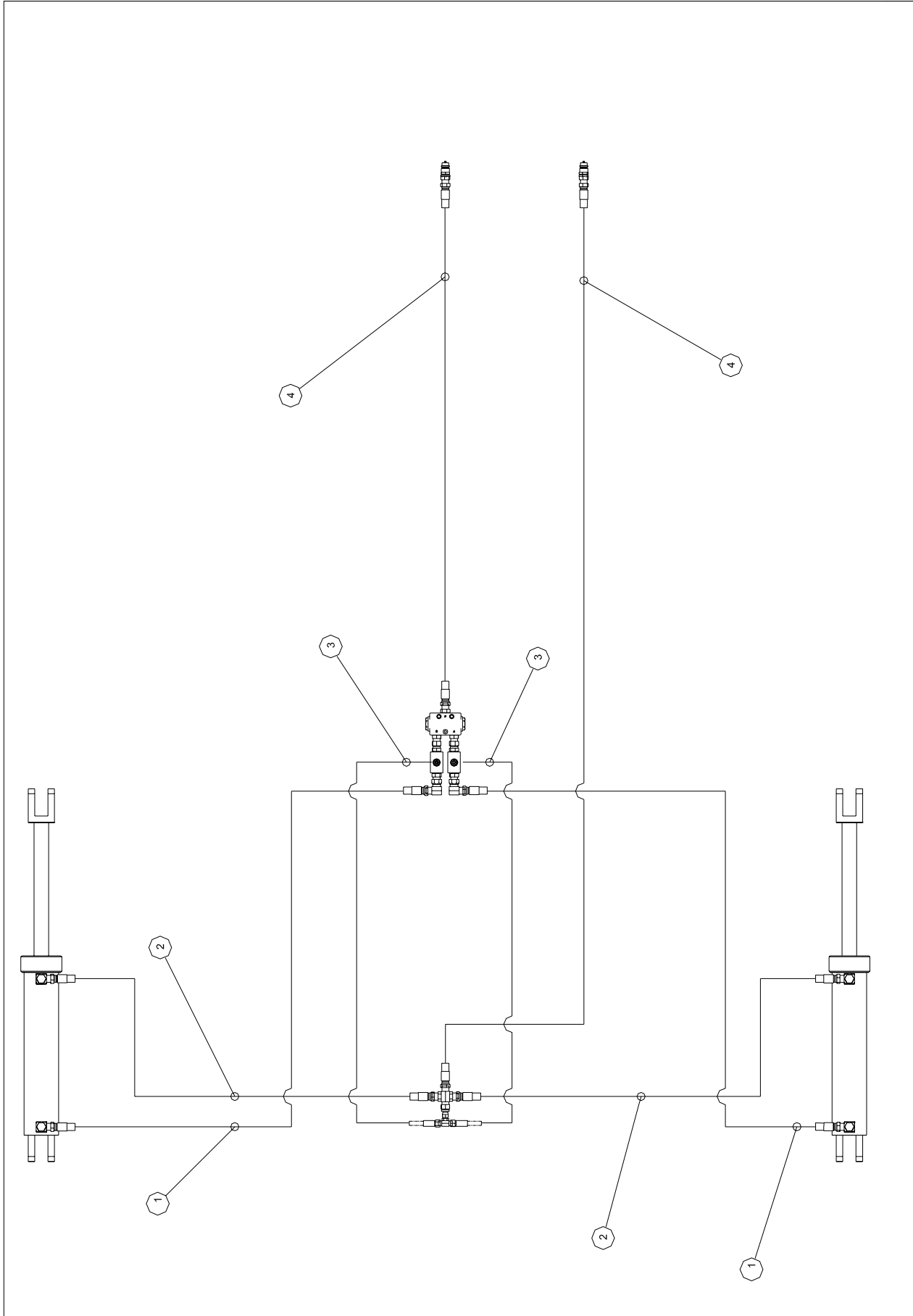

DESCRIPTION: <b>HYDRAULIC HOSE LAYOUT</b>		MACHINE:- SS TOOLBAR	© 2005	DRAWN:- P.J.G DATE:- 16/12/2005	PART NO. FROM SERIAL NO. TO SERIAL NO.	ISSUE <b>AS2394</b> A
--	--	-------------------------	--------	------------------------------------	--	-----------------------------

AS2394		TOOLBAR SERIES 5 - HYDRAULIC HOSE LAYOUT			
ITEM	PART NO	DESCRIPTION	QTY	COMMENTS	
1	P07952	HA 1/2"x3660	2		
2	P00184	HA 1/2"x3660	2		
3	P12010	HA 1/4"x300 90°	2		
4	P00191	HA 1/2"x3660	2		
5					
6					
7					
8					
9					
10					
11					
12					
13					
14					
15					
16					
17					
18					
19					
20					
21					
22					
23					
24					
25					
26					
27					
28					
29					
30					
31					
32					
33					
34					
35					
36					
37					
38					
39					
40					
41					
42					
43					
44					
45					
46					
47					
48					
49					
50					

