

From Serial No. 12213

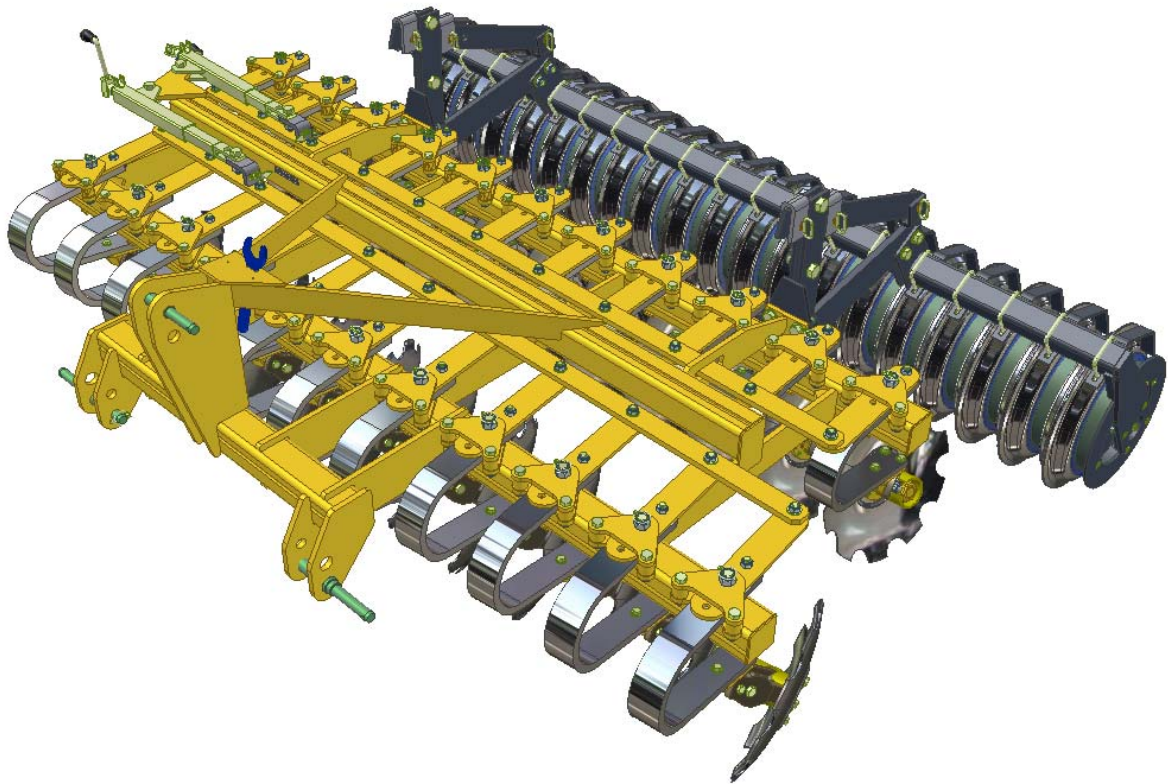

P14174 03/02/06





**DECLARATION OF CONFORMITY**

Simba International Limited hereby declare that the Product described in this Operators Manual, and defined by the Serial Number Plate attached to the Chassis of the Machine (a part copy of which is detailed overleaf and must be completed indicating the relevant machine details), conforms with the following Directives and Regulations, and has been certified accordingly.

**EC Machinery Directive 89/392/EEC, as amended by 91/3688/EEC, 93/44/EEC, and 93/688/EEC.**

In order to fulfill the requirements of health and safety described in the EC Directive, the following standards and technical specifications have been taken into account:

**EN 292 - 1**  
**EN 292 - 2**

**THE MANUFACTURER**

Simba International Limited  
Woodbridge Road  
SLEAFORD  
NG34 7EW  
Lincolnshire  
NG34 7EW  
England.

Telephone 01529 304654.

**CERTIFIED ON BEHALF OF SIMBA INTERNATIONAL LIMITED.**

Philip J. Wright. BSc (Hons) C Eng. MI Agr.E  
Technical Director.



## **WARRANTY**

### **TERMS AND CONDITIONS**

In this warranty Simba International Ltd., is referred to as “the Company”.

1. Subject to the provisions of this warranty the Company warrants each new machine sold by it to be sold free from any defect in material or workmanship for a period of 12 months from date of installation with the end-user.

Some specific items have additional warranty over and above the standard 12 months. Details of these can be obtained upon request directly from the distributor or Simba International Ltd.

2. If the machine or part thereof supplied by the Company is not in accordance with the warranty given in clause 1 the Company will at its option:

- (a) make good the machine or part thereof at the Company's expense, or
- (b) make an allowance to the purchaser against the purchase price of the machine or part thereof, or
- (c) accept the return of the machine and at the buyers option either:
  - I) repay or allow the buyer the invoice price of the machine or part thereof, or
  - II) replace the machine or part thereof as is reasonably practical.

3. This warranty shall not oblige the Company to make any payment in respect of loss of profit or other consequential loss or contingent liability of the Purchaser alleged to arise from any defect in the machine or impose any liability on the Company other than that contained in clause 2.

4. Any claim under this warranty must be notified to the Company in writing specifying the matters complained of within 14 days from the date of repair.

5. Any claim under this warranty must be made by the original purchaser of the machine and is not assignable to any third party.

6. If the purchaser hires out the machine to any third party the warranty shall apply only to matters notified to the Company in writing within 90 days of the date of delivery and clause 1 shall be read as if the period of 90 days were substituted for the period of 12 months.

7. The warranty will cease to apply if:

- (a) any parts not made, supplied or approved in writing by the Company are fitted to the machine or
- (b) any repair is carried out to the machine other than by or with the express written approval of the Company or
- (c) any alterations not expressly authorized by the Company in writing are made to the machine or
- (d) the machine is damaged by accident or
- (e) the machine is abused or overloaded or used for a purpose or load beyond its design capabilities, or used in conjunction with a tractor whose power output capability exceeds the stated implement power requirement by more than 40%. For the purpose of these terms and conditions, “stated implement power requirement” refers to wheeled tractors unless specifically stated. These power requirements should be reduced by 20% when used in conjunction with tracked tractors.
- (f) the machine is operated as part of a ‘cultivation train’ where more than one implement is being towed, without the express written approval of Simba International Ltd.
- (g) any maintenance is not carried out in accordance with the service schedules in the operator's manual.
- (h) the Installation and Warranty Registration Certificate is not received by Simba International Ltd., Service Dept., Woodbridge Road, Sleaford, Lincolnshire, England, NG34 7EW, within 7 days of installing a new machine.

## Machine Identification

Enter the relevant data in the following list upon acceptance of the machine:

Serial Number	
Type of Machine	
Machine Width	
Year of Construction	
Delivery Date	
First Operation	
Accessories	

Operating Instructions/Spare Parts List: February 2006

Dealer Address:      Name: .....  
                         Street: .....  
                         Place: .....  
                         Tel.: .....

Dealer's Customer No.: .....

SIMBA Address:      SIMBA  
                         Woodbridge Road Ind. Est.  
                         Sleaford  
                         Lincolnshire  
                         NG34 7EW

Tel.:            01529 304654  
Fax:            01529 413468  
E-Mail:        simba.international@simba.co.uk

SIMBA Customer No.: .....

# Contents

Machine Identification .....	5
<b>Introduction .....</b>	<b>8</b>
Foreword .....	8
Warranty Guidelines .....	8
<b>1. Safety Data .....</b>	<b>9</b>
1.1 Safety Symbols .....	9
1.2 Use for the Intended Purpose .....	11
1.3 Operational Safety .....	11
1.3.1 No liability for Consequential Damage .....	11
1.4 Traffic Safety .....	12
1.5 Accident Prevention .....	12
1.5.1 Hitching-up the Machine .....	12
1.5.2 Changing Equipment .....	12
1.5.3 During Operation .....	12
1.6 Servicing and Maintenance .....	13
1.7 Operating Areas .....	13
1.8 Authorised Operators .....	13
1.9 Protective Equipment .....	13
<b>2. Transportation/Installation .....</b>	<b>15</b>
2.1 Delivery .....	15
2.2 Transportation .....	15
2.3 Installation .....	15
2.4 Hitching Up .....	16
2.4.1 Hitching-up a Tractor to the X-Press / preparing for Transport .....	16
2.7 When Driving on the Road .....	16
2.8 Parking the Machine .....	16
<b>3. Technical Data .....</b>	<b>17</b>
<b>4. Adjustment/Operation .....</b>	<b>18</b>
4.1 Description .....	18
4.2 3 Point Linkage .....	20
4.3 Disc Units .....	20
4.4 DD Light Roller .....	21
4.5 Work Settings .....	22
4.6 Starting Settings .....	23
4.6.1 Variation of Settings .....	23
4.7 Adjusting Depth .....	24
4.8 Work Instructions .....	24
4.9 Checks .....	25
<b>5. Servicing and Maintenance .....</b>	<b>26</b>
5.1 Servicing .....	26
5.2 Cleaning .....	26
5.3 Disc Hub Maintenance .....	26
5.3.1 Bearing Seals .....	27
5.3.2 Reassembly .....	27
5.4 DD Light Roll .....	27
5.5 Preparation for Storage .....	28
5.6 Operator Support .....	28
5.7 Maintenance Intervals .....	28
5.8 Maintenance Overview .....	29

---

5.9	Overview of Lubricating Points .....	30
5.10	Lubricating the Machine .....	31
5.11	Handling of Lubricants .....	31
5.12	Lubricants & Hydraulic Oil .....	32
<b>6.</b>	<b>Faults and Remedies .....</b>	<b>33</b>
<b>7.</b>	<b>Parts &amp; Assembly .....</b>	<b>35</b>
7.1	Parts & Assembly Contents .....	35

## Introduction

### Foreword

Make sure you have read and follow the Operating Instructions carefully before using the machine. By doing so, you will avoid accidents, reduce repair costs and downtime and increase the reliability and service life of your machine. Pay attention to the safety instructions!

SIMBA will not accept any responsibility for any damage or malfunctions resulting from failure to comply with the Operating Instructions.

These Operating Instructions will assist you in getting to know your machine and in using it correctly for its intended purposes. First, you are given general instructions in handling the machine. This is followed by sections on servicing, maintenance and the action to be taken should a malfunction occur.

These operating instructions are to be read and followed by all persons working on or with the machine, e.g.:

- Operation (including preparation, remedying of faults in the operating sequence and servicing).
- Maintenance (maintenance and inspection)
- Transportation.

Together with the Operating Instructions, you receive a Spare Parts List and a Machine Registration form. Field service technicians will instruct you in the operation and servicing of your machine. Following this, the Machine Registration form is to be returned to SIMBA. This confirms your formal acceptance of the machine. The warranty period begins on the date of delivery.



We reserve the right to alter illustrations as well as technical data and weights contained in these Operating Instructions for the purpose of improving the X-Press.

### Warranty Guidelines

1. The period of liability for material defects (warranty) relating to our products is 12 months. In the case of written deviations from the statutory provisions, these agreements shall apply.

They shall become effective upon installation of the machine with the end customer. All wear parts are excluded from the warranty.

2. Warranty claims must be submitted to the SIMBA Customer Service Department in Sleaford via your dealer. It is only possible to process claims which have been correctly completed and submitted no later than 14 days after the date of repair.

3. In the case of deliveries made under the warranty which are subject to the return of the old parts, the old parts must be returned to SIMBA within 28 days after the damage occurred.

4. In the case of deliveries made under the warranty which are not subject to the return of the old parts, these parts must be kept for the purpose of further decisions for a period of 3 months after receipt of the warranty claim.

5. Warranty repairs to be carried out by outside companies, or repairs which are expected to take more than 10 working hours, must be agreed upon in advance with the Customer Service Department.

# 1. Safety Data

The following warnings and safety instructions apply to all sections of these Operating Instructions.

## 1.1 Safety Symbols

### On the machine



Parts may fly off during operation. Keep a safe distance away from the machine!

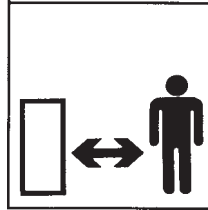

Read and observe the Operating Instructions before starting up the machine!

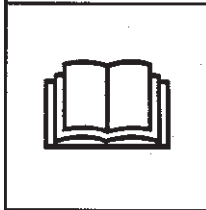

Keep clear of the working range of foldable machine components!



Watch out for escaping pressurised fluids! Follow the instructions in the Operating Instructions!

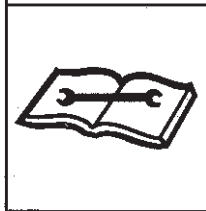

No passengers are allowed on the machine!



Never reach into areas where there is a danger of being crushed by moving parts!

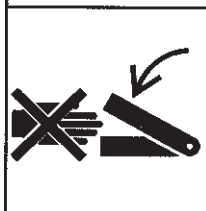

Never reach into any revolving parts!

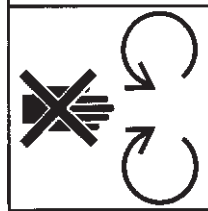



Refer to Operating Instructions before attempting maintenance.

### Operating Instructions:

The Operating Instructions distinguish between three different types of warning and safety instructions. The following graphic symbols are used:



Important!



Risk of injury!



Risk of fatal and serious injuries!

It is important that all the safety instructions contained in these Operating Instructions and all the warning signs on the machine are read carefully.

Ensure that the warning signs are legible. Replace any signs that are missing or damaged.

These instructions must be followed in order to prevent accidents. Inform other users of the warnings and safety instructions.

Do not carry out any operations which may affect safe use of the machine.

## 1.2 Use for the Intended Purpose

The SIMBA X-Press is built using the latest technology and in accordance with the relevant recognised safety regulations. However, risks of injury for the operator or third parties and impairment of the machine or other tangible assets can arise during use.

The machine is only to be operated when in a technically perfect condition and for the intended purpose, taking into consideration safety and risks and following the Operating Instructions. In particular, faults that can impair safety are to be remedied immediately.

Original parts and accessories from SIMBA have been specially designed for this machine. Spare parts and accessories not supplied by us have not been tested or authorised. Installation or use of non-original SIMBA products may have a detrimental effect on specific design features of the machine and affect the safety of machine operators and the machine itself. SIMBA will accept no liability for damage resulting from the use of non-original parts or accessories.

The SIMBA X-Press is designed solely as a cultivation implement. Use for any other purpose, e.g., as a means of transport, will be deemed to be improper use. SIMBA will accept no liability for damage resulting from improper use. The risk will be borne solely by the operator.

## 1.3 Operational Safety

The machine is to be put in operation only after instruction has been provided by an employee of the authorised dealer or an employee of SIMBA. The "Machine Registration" form is to be completed and returned to SIMBA.

All protective and safety equipment, such as removable protective equipment, must be in place and functioning reliably before the machine is put in use.



Check screws and bolts regularly for tightness and retighten if necessary.



In the event of malfunctions, stop and secure the machine immediately.



Ensure that any faults are remedied immediately.

### 1.3.1 No Liability for Consequential Damage

The X-Press has been manufactured by SIMBA with great care. However, problems may still occur when it is used for the intended purpose. These may include:

- Worn wearing parts.
- Damage caused by external factors.
- Incorrect driving speeds.
- Incorrect setting of the unit (incorrect attachment, non-adherence to the Setting instructions).



Therefore, it is crucial to always check your machine before and during operation for correct operation.

Compensation claims for damage which has not occurred to the machine is excluded. This includes any consequential damage resulting from incorrect operation.

## 1.4 Road Traffic Safety

When driving on public roads, tracks and areas, it is important to observe the relevant road traffic laws as well as the specific regulations relating to this machine.



Pay attention to the permitted axle loads, tyre carrying capacity, and total weight in order to maintain adequate braking and steerability.



Passengers on the machine are strictly forbidden!



Max. road transport speed 16mph (25km/h).

## 1.5 Accident Prevention

In addition to the Operating Instructions, it is important to observe the accident prevention regulations specified by agricultural trade associations.

### 1.5.1 Hitching-up the machine

There is a risk of injury when hitching/unhitching the machine. Observe the following:

- Secure the machine against rolling.
- Take special care when reversing the tractor!
- There is a risk of being crushed between the machine and the tractor!
- Park the machine on firm, level ground.

### 1.5.2 Changing Equipment

- Secure the machine to prevent it from accidentally rolling away!
- Use suitable supports to secure any raised frame sections suspended above you!
- Caution! Risk of injury due to projecting parts!



Never climb on to rotating parts such as the roll unit. These parts may rotate causing you to slip and suffer serious injury!

### 1.5.3 During Operation

Ensure that the working range and the area around the machine are clear (children!) before operating the machine.

Always ensure adequate visibility!

Do not stand on the machine while it is in operation!

Operators must have a suitable valid driving licence in order to drive on public roads. In the operating area, the operator is responsible for third parties.

The person in charge must:

- provide the operator with a copy of the Operating Instructions, and
- ensure that the operator has read and understood the instructions.
- make sure that the operator is aware of the specific regulations relating to the machine when driving on public roads.

## 1.6 Servicing & Maintenance

Ensure that regular checks and inspections are always carried out within the periods required by law or specified in these Operating Instructions.

When carrying out service and maintenance work always:

- switch off the tractor engine and remove the ignition key.
- wait until all the machine parts have stopped moving.
- depressurize the hydraulic system.

Prior to performing maintenance and servicing work, ensure that the machine is positioned on solid, level ground and is secured to prevent it rolling away. Do not use any parts to climb on to the machine unless they are specifically designed for this purpose.

Before cleaning the machine with water, steam jets (high-pressure cleaning apparatus) or other cleaning agents, cover all openings into which, for reasons of safety or operation, no water, steam or cleaning agents are to penetrate (bearings, for instance).

Next, check all hydraulic lines for leaks, loose connections, chafe marks and damage. Remedy any deficiencies immediately!

Lubricate all the lubricating points to force out any trapped water.

In the case of hydraulic cylinders that have been cleaned using high pressure equipment ensure that all hydraulic circuits are functional and pressurised fully in both directions. This provides the necessary coating of oil onto cylinder rods after cleaning.

When carrying out servicing and maintenance work, retighten any loose screw connections.

## 1.7 Operating Areas

The operating areas include the drawbar, hydraulic connections and depth adjustment equipment as well as all operating points requiring maintenance.

All operating areas will be specified and described in detail in the following chapters on servicing and maintenance.

Observe all safety regulations included in the Section dealing with Safety, and in the subsequent sections.

## 1.8 Authorised Operators

Only those persons who have been authorised and instructed by the operator may operate the machine. The operator must be at least 16 years of age.

## 1.9 Protective Equipment

For operation and maintenance, you require:

- Tight fitting clothing.
- Strong protective gloves (to provide protection against sharp-edged machine components).
- Protective goggles (to stop dirt getting into your eyes).



## 2. Transportation and Installation

Transportation and initial installation of the machine are described in this chapter.

### 2.1 Delivery

The machine is normally delivered, fully assembled.

- The machine can be lifted off with a crane or other suitable lifting equipment.
- The machine should be hitched to a tractor and driven off a low-loader.

### 2.2 Transportation

The X-Press can be transported on public roads by hitching it up to a tractor or on a low-loader.

- It is important to observe the permitted dimensions and weights when transporting the machine.
- If the machine is transported on a trailer or a low-loader, it must be secured using straps or other devices.
- Before transporting the machine on public roads, it must be adjusted to its transportation position and the stipulations relating to road transportation fulfilled.
- The maximum permissible speed is 25 km /h.

### 2.3 Installation

When carrying out installation and maintenance work there is a higher risk of injury. It is important that you familiarise yourself with the machine and read the Operating Instructions beforehand.

Operator instruction and initial installation of the machine are carried out by our service technicians or authorised distributors.

The machine must not be used in any way beforehand! The machine can only be released for operation after instructions have been provided by our service technicians or authorised distributors.

- If any modules or parts have been removed for transportation, these shall be mounted by our service technicians/authorised dealers before the instruction takes place.
- Check all important screw connections!
- Lubricate all nipples and joints!
- Check all hydraulic connections and lines for damage.

## 2.4 Hitching Up

### 2.4.1 Hitching up a Tractor to the X-Press / Preparing for Transport



When hitching-up the machine, ensure that no-one is between the tractor and the machine.



#### **Tractor Oil Flow Adjustment:**

As a general rule the tractor oil flow rate should be set in the lowest setting before starting. This can then be increased to allow the desired rate of operation as applicable. This will minimise excessive oil flow and consequent power usage and heat generation.

1. Ensure the tractor hydraulics are depressurised and in the locked or closed (not float) setting.
2. Couple the hydraulic hoses to the tractor ensuring that the two wing hoses (yellow) are together (4m Folding model only)
3. Connect the tractor to the machine using the hydraulics to raise or lower the height of the tractor lower link arms.
4. When the lower link arms are aligned fit the lower link pins and the lynch pins.
5. Fit the tractor toplink between the tractor and the machine.
6. Raise the machine using the tractor link arms.



On 4m Folding models if the machine was parked unfolded ensure that it is fully raised, then fold using the wing cylinders.

## 2.5 When driving on the road

When driving on the road the machine must be converted to the transportation position.



When driving on the road, raise the machine completely to prevent the working elements dragging on the ground.



On 3+4m Rigid models ensure that the tractor rear lights are visible from behind during transport.

## 2.6 Parking the machine

In order to avoid damage as a result of moisture, the machine should be parked, if possible, indoors or under cover.



When manoeuvring the machine, pay attention to your surroundings. Ensure that nobody is in the manoeuvring area (watch for children!).

- Park the machine on level and solid ground.
- Lower the machine onto the parking stands ensuring that it is stable (4m Folding models only). On 3+4m Rigid models, lower the machine onto the disc units.
- Remove the toplink and lower the link arms so that pins can be removed.
- Switch off the tractor.
- Disconnect hydraulic and electric lines from the tractor (4m Folding models only).

### 3. Technical Data X-Press

	2.5m	3m	4m	4m FW
<b>Working Width</b>	2500mm	3000mm	4000mm	4000mm
<b>Transport Width</b>	2480mm	2985mm	4040mm	2950mm
<b>Transport Height</b>	N/A	N/A	N/A	2650mm
<b>Length</b>	2530mm	2530mm	2530mm	2640mm
<b>Weight</b>	1525kg	1750kg	2440kg	2920kg
<b>No. of Discs</b>	18	22	30	32
<b>Tractor Power Required (H.P.)*</b>	60-80	80-100	110-140	110-140

\* It is important to correctly match your implement to your tractor for optimum performance.

## 4. Adjustment/Operation

### 4.1 Description

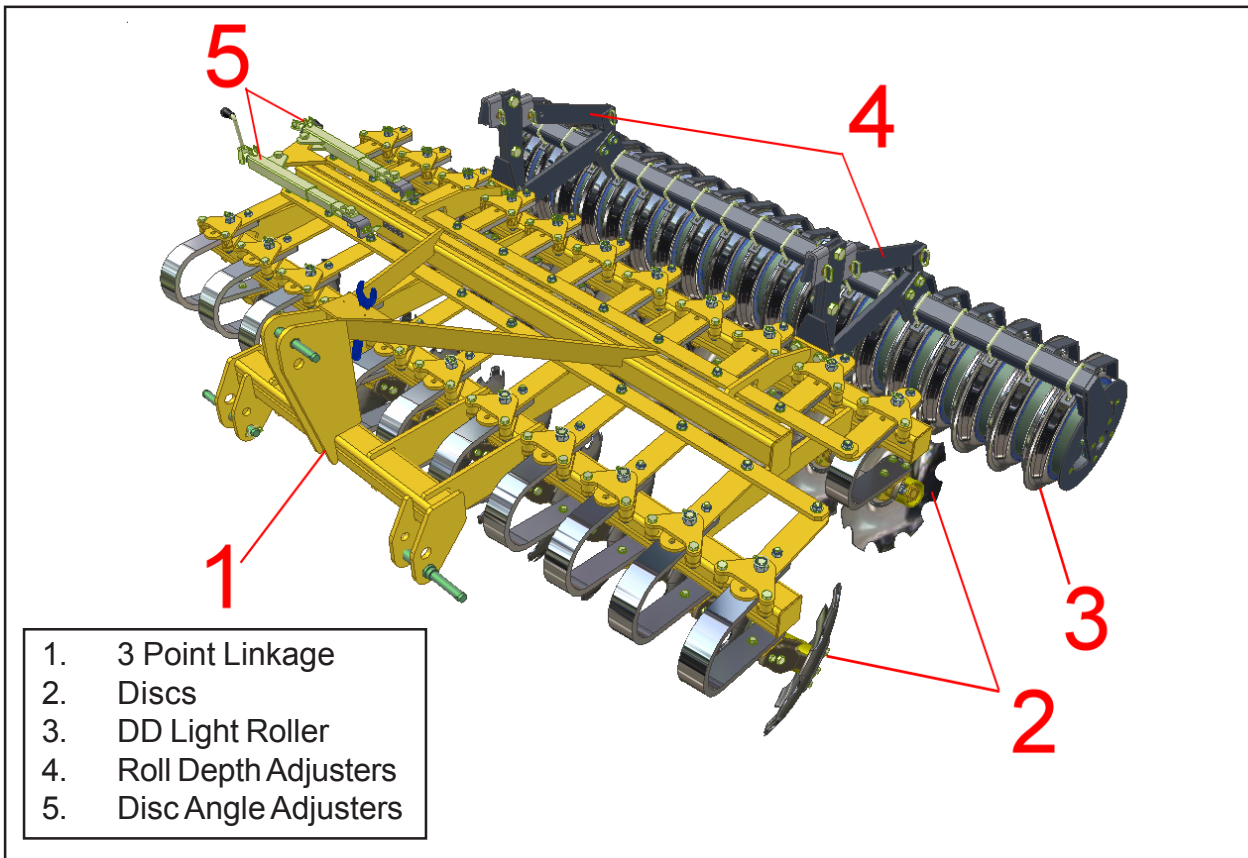

Fig. 4.01: Simba Mounted X-Press - Rigid

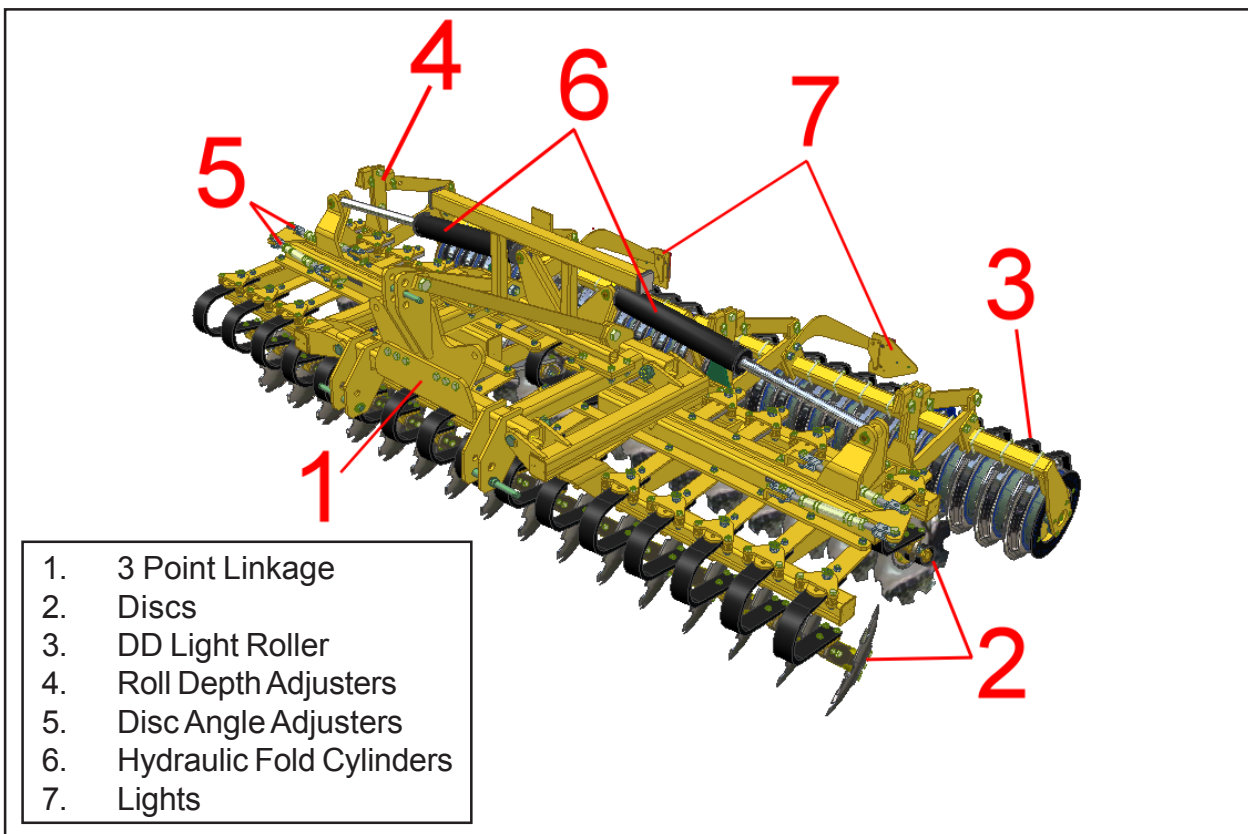

Fig. 4.02: Simba Mounted X-Press - Folding

The SIMBA X-Press is a versatile implement designed to perform an excellent shallow cultivation combined with effective consolidation.

It can be used in reduced tillage systems to incorporate stubble or to work down ploughing on lighter soil types. Like all Simba machines it features the latest innovations which combine to give an efficient, well-built unit with unrivalled reliability.

Consolidation is key to most operations. The design of the X-Press ensures that this is not compromised during use. This is because the penetration of the front discs is achieved by angling the disc gangs and not by transferring weight from the rear roller onto the discs. The in line rear roller ensures uniform consolidation is achieved across the field.

The X-Press can operate in situations where high levels of surface trash exist. This is possible because of the massive clearance within the machine. The front and rear disc gangs are 830mm apart and the distance between the rear gang and the DD roller is another 240mm.

The X-Press is designed for high speed operation at 8-12kph. The in-built weight of around 600kg per metre ensures that the desired depth is maintained at the optimal forward speed.

The DD Light roller gives an even consolidation across the full machine width giving a fine, firmed finish from the 150mm DD spacing.

## 4.2 3 Point Linkage

The standard Category 3 linkage at the front of the X-Press also has the ability to fit Category 2 tractor linkages by reversing the upper and lower link pins in their respective positions.

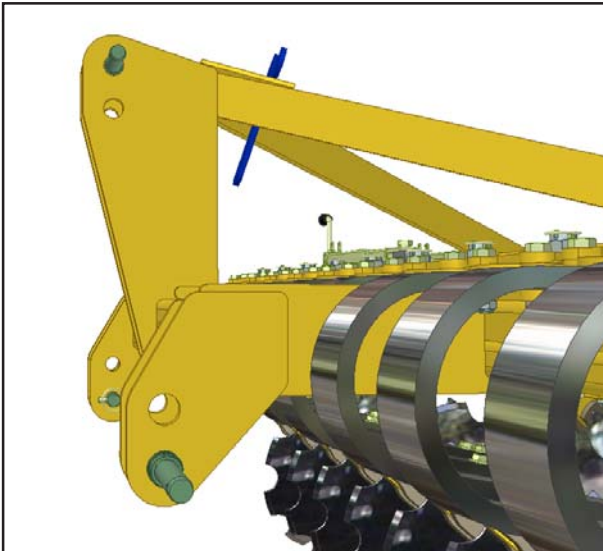

Fig. 4.03: 3 Point Linkage

## 4.3 Disc Units

The X-Press features two rows of discs which chop and mix the crop residue. A disc spacing of 250mm ensures a fine tilth.

The discs fitted to the X-Press are 500mm in diameter (20") and 6mm thick. They are manufactured from heat treated chrome boron steel which ensures excellent wear resistance and enhanced working life. Each disc is mounted on a Pro-Flex sprung leaf linked to a track rod system. Gang angles can be varied with ease and accuracy using a graduated adjuster.

Adjustable angling of the discs (between 10°-25°) ensures penetration and stubble mixing are achieved in one pass. Working depth can be varied via the 3 point linkage and the rear roll linkage.

A level, evenly cultivated finish is maintained by adjusting the balance of soil throw between the front and rear disc.

All disc arms are shear bolt protected so they break back if they meet obstructions. Sprung Pro-Flex leaves offer further protection against damage as well as offering a degree of contour following as they flex up and down in work.

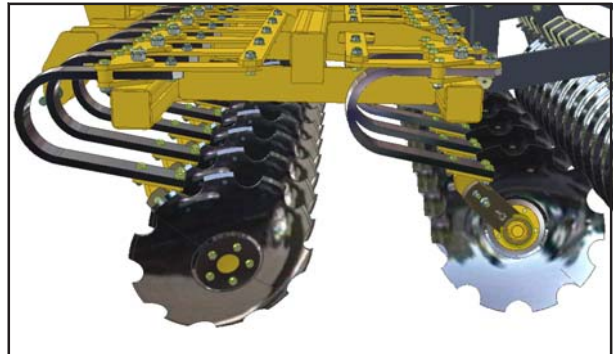

Fig. 4.04: Discs

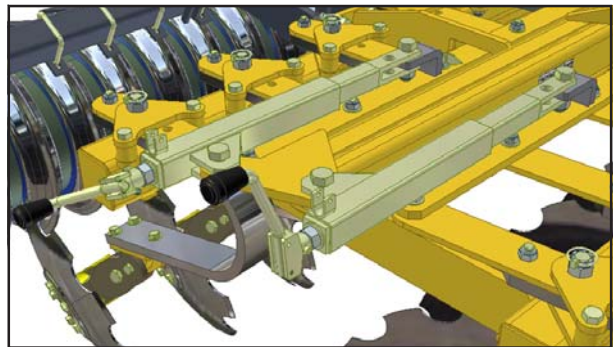

Fig. 4.05: Disc Angle Adjustment Jacks

## 4.4 DD Light Roller

The DD Light roller is made up of individual Double Disc (patented) Ring segments.

The DD Light roll is designed to consolidate the soil whilst cutting and crushing any clods.

Even in heavy, wet soils it can easily be operated with minimal blockages occurring.

The rear DD Light roller carries a proportion of the machine's weight to ensure consolidation. It also regulates the depth of the disc units. The corrugated surface left by the roller is weatherproof both for wet or dry situations.

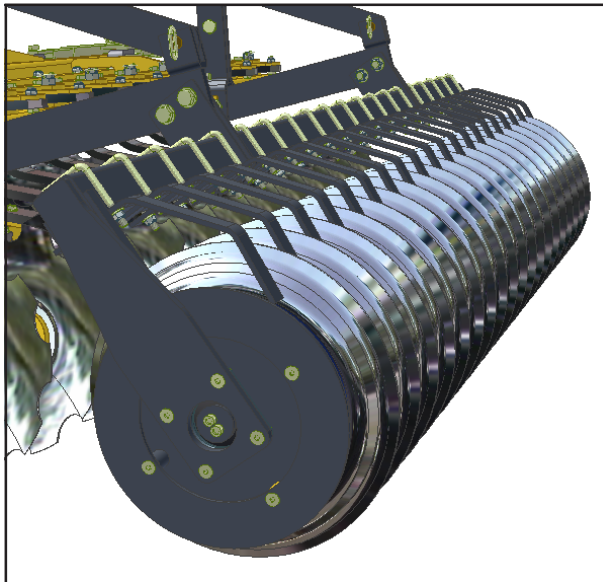

Fig. 4.06: DD Light Roller

## 4.5 Work Settings

Optimum performance has been found to be achieved when the DD Light roll rings have worn away the painted finish leaving a smooth shiny surface. When the DD Light rings are new or rusty, soil may tend to pick up on the surface and blockage may occur, this will reduce when the rings are shiny again.

The X-Press should be run with the chassis level to slightly tail low. In practice it is possible to use the X-Press on ground conditions that are unsuitable to achieve the desired effect, and it is usually possible to operate the DD Light roll without regular blockage under such unsuitable conditions, assuming that the roll assemblies are tight, the scrapers correctly adjusted and rings smooth. As such, especially under wet conditions, it is advisable to check on the cultivation effect of the X-Press.

The mounted X-Press should be lifted fully clear of the ground for all headland turns. Turning with the disc units or roller on the ground could lead to damage of these components.

In work, the tractor lower link arms may be run in float in order to allow the machine to follow undulations in the soil.

### General Rules when Setting the X-Press

- The lighter the land conditions the less the disc angle required and the forward speed can be increased.
- The wetter the land conditions the less the disc angle required and the forward speed will need to be decreased.
- Heavier land will require more of a disc angle and a slower forward speed.
- The more the trash the less the angle on the discs and forward speed will have to be decreased.
- On ploughed land reduce the disc angle to give a cutting/chopping action.
- In hard conditions increase the disc angle to increase penetration.

### Disc Angle Setting

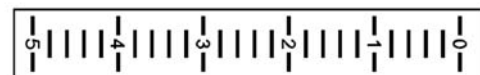

← INCREASE DISC ANGLE  
DECREASE DISC ANGLE →

## 4.6 Starting Settings

This page details the recommended starting settings for the X-Press. These settings can then be used as a base for further adjustment in order to get the optimum performance from your machine.

### 3 Point Linkage / DD Light Roller

The machine should be set to run level front to rear and left to right.

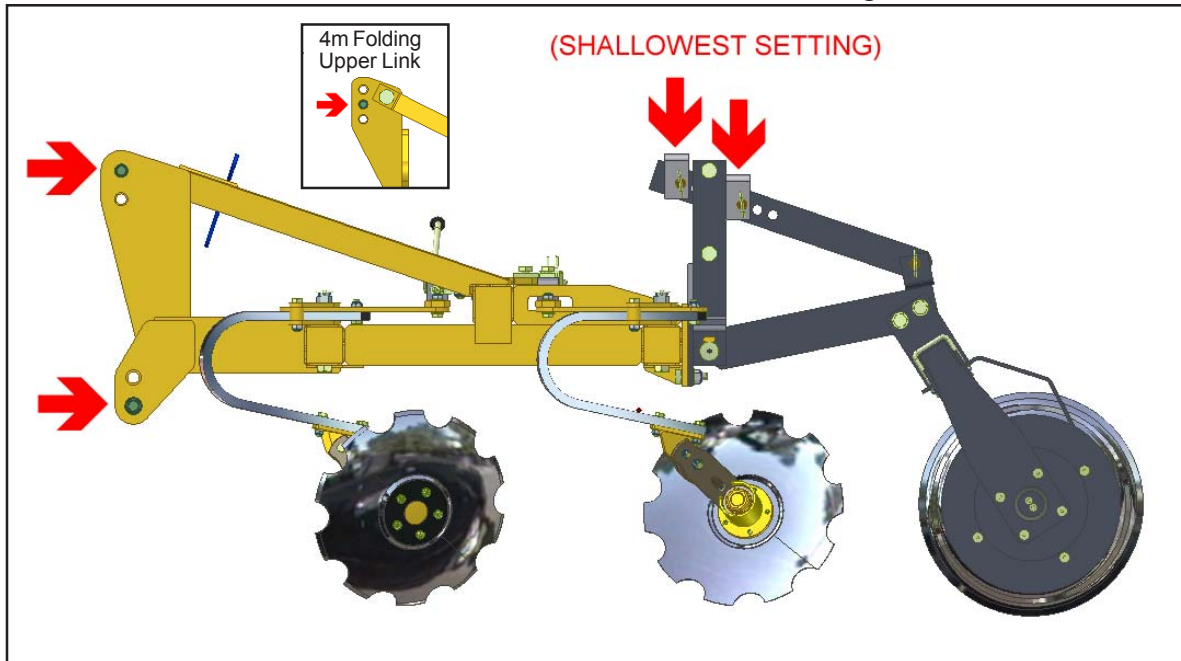

### Disc Angle Adjustment Jacks

Front Gang



Rear Gang



#### 4.6.1 Variation of Settings

If working conditions change (for example, from dry to wet conditions) then the following table should be consulted as a rough guide.

VARIATION IN CONDITION	SETTING REVISION
FROM HARD/DRY TO LOOSE/WET	REDUCE DISC ANGLE
	REDUCE CHASSIS PITCH
FROM STUBBLES TO HIGHER TRASH (TO INCREASE INCORPORATION)	INCREASE DISC ANGLE
	REDUCE SPEED
	INCREASE CHASSIS PITCH
FROM SHALLOW TO DEEP (NOTE 75- 100mm MAX WORKING DEPTH)	MOVE PINS ON ROLL LINKAGE
	REDUCE SPEED
	INCREASE DISC ANGLE

## 4.7 Adjusting Depth

To change the working depth it is advisable to lift the machine clear of the ground so that the rear roll linkage becomes loose. Move the position of the depth stop and/or pin to change the depth. Reversing the depth stop through 180° and refitting gives a finer depth adjustment.

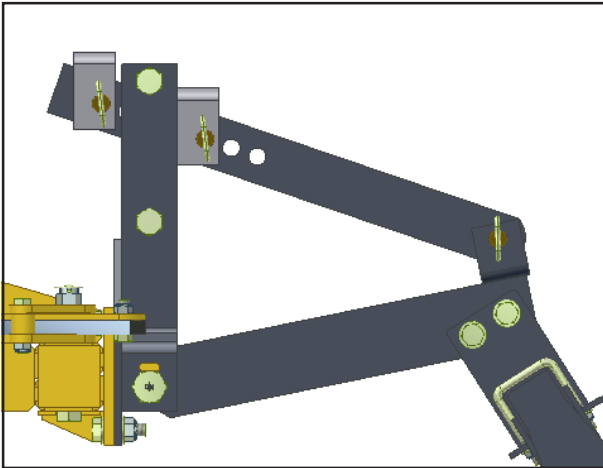

Fig. 4.07: Roll Linkage

When the depth has been altered, lower the machine into work and check operation. If the depth change has been significant then other setting could be affected. This could be chassis pitch (front to rear) and disc angle for the given depth.

A small amount of cultivation, eg. a 20 metre run, should be carried out before altering these settings to check whether they are now suitable for the cultivation effect required. These settings should be addressed immediately to prevent too much work being carried out.

## 4.8 Work Instructions

### Driving speed

The X-Press can be driven at speeds of up to 12 km/h.

This depends on the field conditions (type of soil, surface trash, etc.).

Drive more slowly if the conditions are difficult or a firmer finish is required.

Turning:



Before turning, the machine should be lifted out of work while driving. Likewise, it should be lowered back into work once the turn has been completed.

### Parking the machine

In order to avoid damage as a result of moisture, the machine should be parked, if possible, indoors or under cover.



When manoeuvring the machine, pay attention to your surroundings. Ensure that nobody is in the manoeuvring area (watch for children!).

- Park the machine on level and solid ground.
- Lower the machine onto the parking stands ensuring that it is stable (4m Folding models only). On Rigid models, lower the machine onto the disc units.
- Remove the toplink and lower the link arms so that pins can be removed.
- Switch off the tractor.
- Disconnect hydraulic and electric lines from the tractor (4m Folding models only).

## 4.9 Checks

The working quality depends on the adjustments and checks made prior to and during work, as well as on regular servicing and maintenance of the machine.

Before beginning work it is therefore important to carry out any necessary servicing and to lubricate the machine as required.

### **Checks prior to, and during work:**

- Is the machine correctly hitched up and the coupling device locked?
- Have the hydraulic lines been connected according to the colour coding?
- Is the machine in a level operating position and the working depth set correctly?

### **Working Elements**

- Are the discs and other cultivation tools in a serviceable condition?
- Are the scrapers still operable, so that the rolls do not jam?

## 5. Servicing and Maintenance



Follow the safety instructions for servicing and maintenance.

### 5.1 Servicing

Your machine has been designed and constructed for maximum performance, operational efficiency and operator friendliness under a wide variety of operating conditions.

Prior to delivery, your machine has been checked at the factory and by your authorised dealer to ensure that you receive a machine in optimum condition.



To ensure trouble-free operation, it is important that servicing and maintenance work is performed at the recommended intervals.

### 5.2 Cleaning

In order to ensure that the machine is always in operating condition and to achieve optimum performance, perform the cleaning and servicing work at regular intervals.

Avoid cleaning the roll / disc bearings with a high-pressure hose or a direct water jet. The housing, screwed connections and ball bearings are not watertight.

In the case of hydraulic cylinders that have been cleaned using high pressure equipment ensure that all hydraulic circuits are functional and pressurised fully in both directions. This provides the necessary coating of oil onto cylinder rods after cleaning.

### 5.3 Disc Hub Maintenance

1. Grease every disc hub until grease shows from the seals according to the lubricating intervals outlined on page 38.
2. Check disc hubs regularly for tightness.
3. Check main bearing adjustment (twin taper roller) after 50 hours and thereafter seasonally by 'rocking' the disc as per *Fig. 5.01*. If play is evident then the following procedure should be followed. Loosen the small grub screw locking the bearing cap to the housing. Remove bearing caps and locking pins, tighten nuts to inhibit rotation before backing off the nuts slightly until disc rotation is enabled and play is eliminated (usually between 1/6 - 1/12 of a turn). Re-fit the locking pins. Fit and securely tighten disc hub caps and flush with grease until grease shows from seal area.
4. Regularly examine hub caps, seals, shear and pivot bolts and all tracking bolts for tightness and effectiveness twice weekly or every 50 working hours (whichever is more frequent).

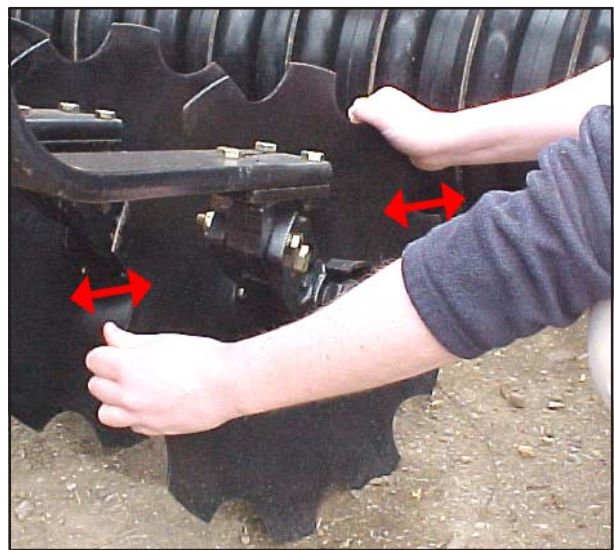

*Fig. 5.01: Checking Disc Bearing Adjustment*

### 5.3.1 Bearing Seals

It is important when replacing the labyrinth type bearing seals in X-Press disc hubs that the seal is fitted the right way round. The chamfered lip side should be at the outside of the bearing housing (see *Fig. 5.02*). This chamfered lip prevents dirt ingress into the housing and also allows grease to be flushed through when greasing.

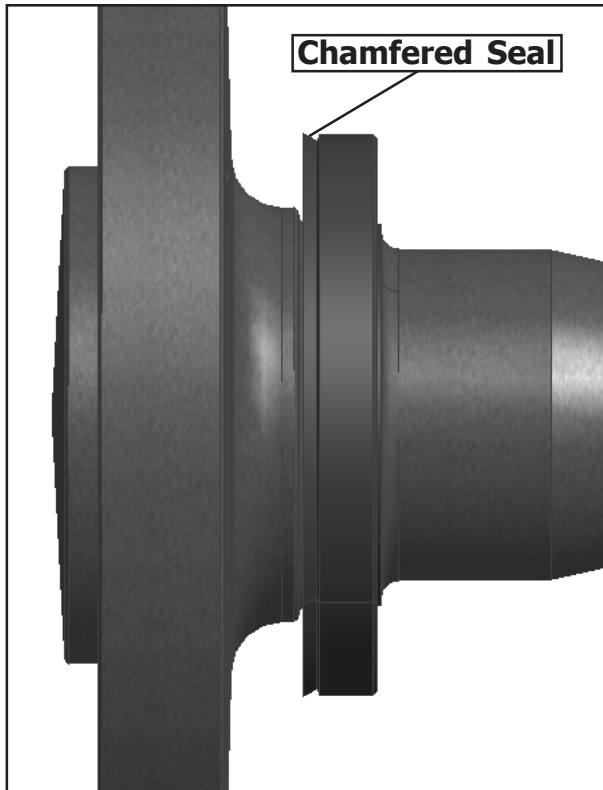

*Fig. 5.02: Correct Seal Orientation*

### 5.3.2 Reassembly

Simba recommend that the seal and outermost bearing are assembled on the spindle (as per *Fig. 5.03*) before inserting it into the housing and reassembling the unit.

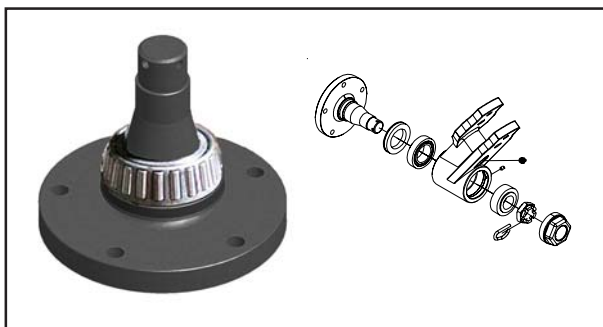

*Fig. 5.03: Spindle w/Bearing & Seal*

### 5.4 DD Light Roll

The axles on this roller are tensioned by the main axle through the centre of the rings and bearings. The DD Light roll is tensioned by the end plates at the outer ends of the and by the rubber spacers between each ring.



Specialist equipment is required for the disassembly of DD Light rollers. Please consult your dealer under any circumstances that require disassembly of these axles.

Maintenance of these rollers is limited to yearly/end of season greasing of the bearings and regular inspection to ensure the assemblies are tight, and scrapers are correctly set.



The scraper is intended to clear dirt from blocking between adjacent DD rings. If adjustment to the scrapers is required ensure that the metal scraper cannot contact the rubber spacer even under load. Regularly inspect the rubber spacers for signs of wear and adjust any scrapers to ensure no contact can be made.

## 5.5 Preparation for Storage

If you need to store the machine for a longer period, observe the following points:

- Park the machine undercover if possible.
- Protect the roll / discs against rust. If you need to spray the implements with oil, use light biologically degradable oils, e.g. rape oil.



Cover any rubber sections before using oil sprays. These sections must not be oiled.

Remove any traces of oil with a suitable cleaning agent.

## 5.6 Operator Support

If you have a problem, please contact your dealer. They will endeavour to solve any problems which may occur and provide you with support at all times.

In order to enable your dealer to deal with problems as quickly as possible, it helps if you can provide them with the following data. Always state the:

- Customer Number
- Name and Address
- Machine Model
- Serial Number of Machine
- Date of Purchase and Operating Hours
- Type of Problem

## 5.7 Maintenance Intervals

Apart from daily maintenance, the maintenance intervals are based on the number of operating hours and time data.

Keep a record of your operating hours to ensure that the specified maintenance intervals are adhered to as closely as possible.

Never use a machine that is due for maintenance. Ensure that all deficiencies found during regular checks are remedied immediately.



Avoid sharp-edged and pointed parts (disc blades, etc.) when working on the machine.



Place the machine on suitable supports when working underneath! Do not work under a machine which is not supported!

## 5.8 Maintenance Overview

X-Press Maintenance Overview			
After first operation	Instructions	Interval	Note
Check all screw, bolt and plug connections	Check they are firmly seated. Tighten / Secure if necessary	---	---
Lubricate machine	See overview of lubricating points	---	Page 30
<b>During operation</b>			
Lubricate machine	See overview of lubricating points	---	Page 30
Disc Angle Adjusters, Working Depth	Check setting and ensure they are firmly secured	daily	Page 22-24
Hydraulic system and components (if applicable)	Check seals, signs of crushing/wear, function and condition	daily	---
Disc Hub Units / Pro-Flex Leaves	Check condition, mountings and smooth operation	daily	Pages 20
Roll bearings	Check condition, mountings and smooth operation	daily	Pages 21
DD Light roller ring segments	Check condition and ensure they are firmly secured	daily	Pages 20
Safety devices (transport strap) (if applicable)	Check condition and function	daily	---
<b>After season</b>			
Lubricate machine	See overview of lubricating points	---	Page 30
Toplinks / Bolts	Grease any exposed threads	---	---
Entire machine	Carry out cleaning and maintenance	---	---
Spray DD Light roll with oil	Use biological oil if possible - cover rubber elements	---	---
<b>After 4 years</b>			
Hydraulic pipes (if applicable)	Replace	MRL Anh I	EN 1533

## 5.9 Overview of Lubricating Points

X-Press lubrication points	Interval	Diag. No.
DD Light Roll Bearings (One pump only!)	End of season	5.04
DD Light Roll Pivot	End of season	5.05
Disc Hub Bearings	100 hrs. *	5.06
Disc Angle Adjusters	End of season	5.07
Wing Cylinder Pivots (4m Folding models only)	End of season	5.08
Wing Hinges (4m Folding models only)	End of season	5.09

\* See page 32, section 5.12 for details



Fig. 5.04: DD Light Grease Points

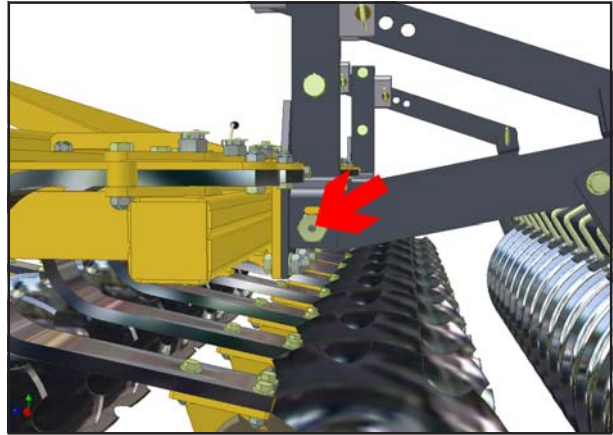

Fig. 5.05: Roll Pivot Grease Points

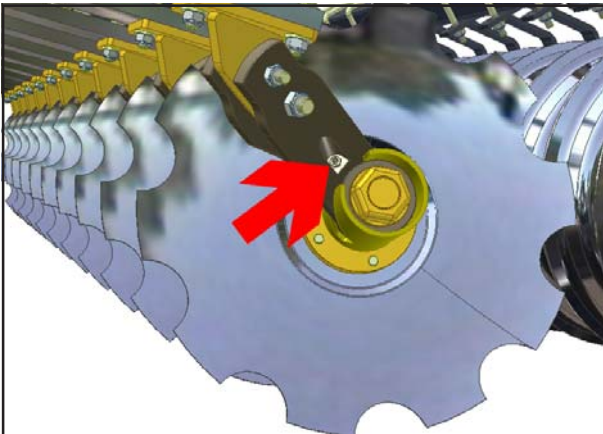

Fig. 5.06: Disc Hub Grease Points

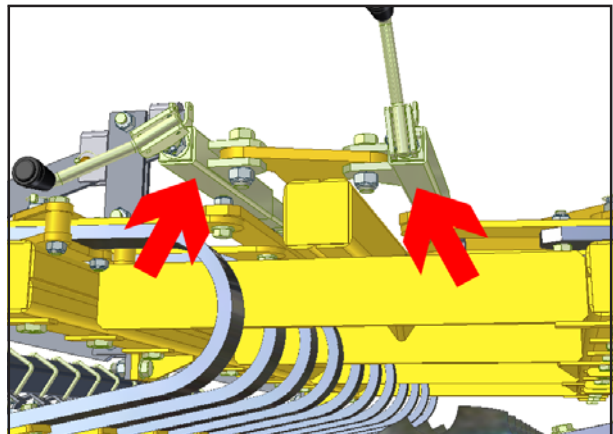

Fig. 5.07: Disc Angle Adj. Jacks Grease Points

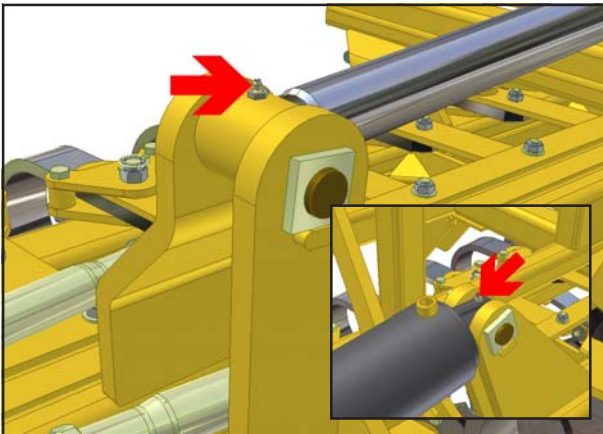

Fig. 5.08: Wing Cylinder Pivots

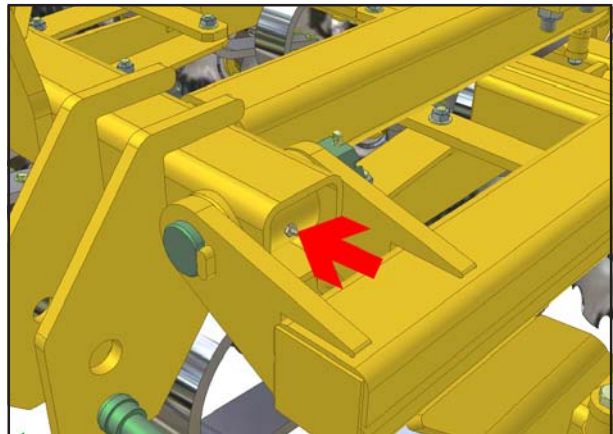

Fig. 5.09: Wing Hinges

## 5.10 Lubricating the Machine

Please read the section entitled "Using Lubricants" carefully before lubricating the machine.

The machine must be lubricated regularly in order for it to remain serviceable. Regular lubrication also contributes towards extending the service life of your machine.

The recommended lubricating intervals are specified in "Inspection" and "Maintenance Intervals".

After it has been washed using a high-pressure hose or steam cleaned, the machine should always be lubricated using a grease gun. Ensure that the universal joints and splined shafts are lubricated regularly.

## 5.11 Handling of Lubricants

Please ensure that you read the following instructions as well as the relevant information. This also applies to any of your employees who handle lubricants.

### Hygiene

Lubricants do not present a health hazard provided they are used for their specified purpose.

In the case of prolonged skin contact, lubricants - especially low-viscosity oils - may remove the natural layer of fat contained in the skin, resulting in dryness and possible irritation.

It is important to take extreme care when handling waste oil as it may contain other irritants.

Vapours given off by cleaning agents and oils are also a potential health hazard.

You should therefore not carry any oily cloths around. Change soiled work clothing as soon as possible.

Always exercise extreme care and observe the recommended hygiene rules when handling mineral oil products. Details of these handling regulations can be found in information provided by the health authorities.

### Storage and Handling

- Always store lubricants where they cannot be accessed by children.
- Never store lubricants in open or unlabelled containers.

### Fresh Oil

- Apart from taking the usual care and observing hygiene rules, there is no need to take any special precautions when handling fresh oil.

### Waste Oil

- Waste oil can contain harmful contaminants which may cause skin cancer, allergies and other illnesses.

### Attention!

Oil is a toxic substance. Should you swallow any oil, do not try to vomit. Contact a doctor immediately.

Protect your hands with barrier cream or wear gloves to avoid contact with the skin. Wash off any traces of oil thoroughly with soap and hot water.

- Wash your skin thoroughly with soap and water.
- Use special cleaning agents to clean any dirt off your hands.
- Never wash oil residue from your skin with petrol, diesel fuel or paraffin.
- Avoid skin contact with any oily clothing.
- Do not keep any oily rags in your pockets.
- Wash soiled clothing before wearing it again.
- Ensure that any oily footwear is disposed of in the proper manner.

## Measures in case of injury through oil

### Eyes:

Should any oil be splashed into your eyes, rinse with water for 15 minutes. If the eye is still irritated, contact a doctor immediately

### If oil is swallowed

If oil is swallowed, it is important not to induce vomiting. Contact a doctor immediately.

### Skin irritation caused by oil

In case of prolonged skin contact, wash off the oil with soap and water.

### Oil Spills

Use either sand or a suitable granular absorbent to soak up any spilt oil. Dispose of the oil-contaminated absorbent in the proper manner.

### Oil Fires

Never use water to extinguish an oil fire. The oil will float on the water causing the fire to spread.

Burning oil-lubricant must be extinguished using a carbon dioxide powder or foam extinguisher. Always wear respiratory equipment when dealing with fires of this type.

### Waste Oil Disposal

Oil-contaminated waste and used oil must be disposed of in accordance with current legislation.

Waste oil must be collected and disposed of in accordance with local regulations. Never pour used oil into unsealed sewage systems or drains or onto the ground.

## 5.12 Lubricants & Hydraulic Oil

### Hydraulic System (4m Folding models)

The hydraulic fluid from the tractor is mixed with the hydraulic fluid from the machine.

The supplied machine hydraulic system contains Total AZOLLA ZS 32 oil.

### Lubricants

Simba strongly recommend the use of **Lithium Complex EP2 Grease** in the disc hubs of your X-Press. This grease is a Lithium Complex soap dispersed in a mineral oil and is interpreted by IARC as being non-carcinogenic. Grease cartridges are available from Simba (P12710). Using this grease in combination with the labyrinth type seal it is permissible to lengthen the greasing interval on the disc hubs to 100 hours. If using a standard agricultural grease the disc hubs should be lubricated every 50 hours.

#### Advantages of Lithium Complex EP2 Grease

- Excellent mechanical stability.
- Excellent load carrying properties.
- Wide temperature range.
- Excellent oxidation stability.
- Excellent water resistance.
- Compatibility with other greases.

All other lubricating points on the machine can be lubricated with multigrade lubricating grease as specified in DIN 51825 KP/2K - 40.

## 6. Faults and Remedies

X-Press Troubleshooting		
Fault	Possible cause	Remedy
Machine 'bouncing' in work	Disc angle too great	Reduce disc angle
	Speed too fast	Reduce speed (<12kmh)
Machine pulls to the left	Front gang angle or depth too great	Reduce front gang angle or depth
	Rear gang angle or depth too shallow	Increase rear gang angle or depth
Machine pulls to the right	Front gang angle or depth too shallow	Increase front gang angle or depth
	Rear gang angle or depth too great	Reduce rear gang angle or depth
DD Light roll blocks regularly	Conditions may not be ideal ideal for using machine	Wait for more favourable conditions
	Scrapers incorrectly adjusted	Adjust scrapers to clear dirt from between DD rings (see section 5.4 on page 27)
Inadequate consolidation	Not enough weight on rear roll	Increase chassis pitch slightly via tractor toplink
	Not enough cultivated soil depth	Increase working depth
	Speed too fast	Reduce speed (<12kmh)

**Space for Notes:**

**Space for Notes:**