



P13937 19/12/05



**DECLARATION OF CONFORMITY**

Simba International Limited hereby declare that the Product described in this Operators Manual, and defined by the 5 digit Registration number stamped onto the inside of the roller, conforms with the following Directives and Regulations, and has been certified accordingly.

**EC Machinery Directive 89/392/EEC, as amended by 91/3688/EEC, 93/44/EEC, and 93/688/EEC.**

In order to fulfill the requirements of health and safety described in the EC Directive, the following standards and technical specifications have been taken into account:

**EN 292 - 1**  
**EN 292 - 2**

**THE MANUFACTURER**

Simba International Limited  
Woodbridge Road  
SLEAFORD  
NG34 7EW  
Lincolnshire  
NG34 7EW  
England.

Telephone 01529 304654.

**CERTIFIED ON BEHALF OF SIMBA INTERNATIONAL LIMITED.**

Philip J. Wright. BSc (Hons) C Eng. MI Agr.E  
Technical Director.



## **WARRANTY** **TERMS AND CONDITIONS**

In this warranty Simba International Ltd., is referred to as “the Company”.

1. Subject to the provisions of this warranty the Company warrants each new machine sold by it to be sold free from any defect in material or workmanship for a period of 12 months from date of installation with the end-user.

Some specific items have additional warranty over and above the standard 12 months. Details of these can be obtained upon request directly from the distributor or Simba International Ltd.

2. If the machine or part thereof supplied by the Company is not in accordance with the warranty given in clause 1 the Company will at its option:

- (a) make good the machine or part thereof at the Company's expense, or
- (b) make an allowance to the purchaser against the purchase price of the machine or part thereof, or
- (c) accept the return of the machine and at the buyers option either:
  - I) repay or allow the buyer the invoice price of the machine or part thereof, or
  - II) replace the machine or part thereof as is reasonably practical.

3. This warranty shall not oblige the Company to make any payment in respect of loss of profit or other consequential loss or contingent liability of the Purchaser alleged to arise from any defect in the machine or impose any liability on the Company other than that contained in clause 2.

4. Any claim under this warranty must be notified to the Company in writing specifying the matters complained of within 14 days from the date of repair.

5. Any claim under this warranty must be made by the original purchaser of the machine and is not assignable to any third party.

6. If the purchaser hires out the machine to any third party the warranty shall apply only to matters notified to the Company in writing within 90 days of the date of delivery and clause 1 shall be read as if the period of 90 days were substituted for the period of 12 months.

7. The warranty will cease to apply if:

- (a) any parts not made, supplied or approved in writing by the Company are fitted to the machine or
- (b) any repair is carried out to the machine other than by or with the express written approval of the Company or
- (c) any alterations not expressly authorized by the Company in writing are made to the machine or
- (d) the machine is damaged by accident or
- (e) the machine is abused or overloaded or used for a purpose or load beyond its design capabilities, or used in conjunction with a tractor whose power output capability exceeds the stated implement power requirement by more than 40%. For the purpose of these terms and conditions, “stated implement power requirement” refers to wheeled tractors unless specifically stated. These power requirements should be reduced by 20% when used in conjunction with tracked tractors.
- (f) the machine is operated as part of a ‘cultivation train’ where more than one implement is being towed, without the express written approval of Simba International Ltd.
- (g) any maintenance is not carried out in accordance with the service schedules in the operator's manual.
- (h) the Installation and Warranty Registration Certificate is not received by Simba International Ltd., Service Dept., Woodbridge Road, Sleaford, Lincolnshire, England, NG34 7EW, within 7 days of installing a new machine.

## Machine Identification

Enter the relevant data in the following list upon acceptance of the machine:

Serial Number	
Type of Machine	
Machine Width	
Year of Construction	
Delivery Date	
First Operation	
Accessories	

Operating Instructions/Spare Parts List: December 2005

Dealer Address:      Name: .....  
                         Street: .....  
                         Place: .....  
                         Tel.: .....

Dealer's Customer No.: .....

SIMBA Address:      SIMBA  
                         Woodbridge Road Ind. Est.  
                         Sleaford  
                         Lincolnshire  
                         NG34 7EW

Tel.:            01529 304654  
Fax:            01529 413468  
E-Mail:        simba.international@simba.co.uk

SIMBA Customer No.: .....



# Contents

Machine Identification .....	5
<b>Introduction .....</b>	<b>8</b>
Foreword .....	8
Warranty Guidelines .....	8
<b>1. Safety Data .....</b>	<b>9</b>
1.2 Use for the Intended Purpose .....	9
1.3 Operational Safety .....	10
1.4 No Liability for Consequential Damage .....	10
1.5 Changing Equipment .....	10
1.6 During Operation .....	10
1.7 Servicing & Maintenance .....	10
<b>2. Transportation and Installation.....</b>	<b>11</b>
2.1 Delivery .....	11
2.2 Transportation .....	11
2.3 Installation .....	11
2.4 Hitching-up the machine .....	11
<b>3. Adjustment/Operation .....</b>	<b>12</b>
3.1 Description .....	12
3.2 Working Elements .....	13
3.2.1 Tines .....	13
C Leaf Tines & Clip-on Sweeps .....	13
Pigtail Tines .....	13
Pro-Lift Tines & Wings .....	14
Furrower Tines .....	14
3.2.2 Disc Ridgers .....	15
3.2.3 Depth Wheels .....	15
3.3 Work Instructions .....	16
3.4 Checks .....	16
3.5 Parking .....	16
<b>4. Servicing and Maintenance .....</b>	<b>17</b>
4.1 Servicing .....	17
4.2 Cleaning .....	17
4.3 Storage / Parking .....	17
4.4 Operator Support .....	17
4.5 Maintenance Intervals .....	17
4.6 Maintenance Overview .....	18
4.7 Overview of Lubricating Points .....	19
Lubricants .....	19
<b>5. Parts and Assembly .....</b>	<b>21</b>

## Introduction

### Foreword

Make sure you have read and follow the Operating Instructions carefully before using the machine. By doing so, you will avoid accidents, reduce repair costs and downtime and increase the reliability and service life of your machine. Pay attention to the safety instructions!

SIMBA will not accept any responsibility for any damage or malfunctions resulting from failure to comply with the Operating Instructions.

These Operating Instructions will assist you in getting to know your component and in using it correctly for its intended purposes. First, you are given general instructions in handling the component. This is followed by sections on servicing, maintenance and the action to be taken should a malfunction occur.

These operating instructions are to be read and followed by all persons working on or with the component, e.g.:

- Operation (including preparation, remedying of faults in the operating sequence and servicing).
- Maintenance (maintenance and inspection)
- Transportation.

Together with the Operating Instructions, you receive a Spare Parts List and a Machine Registration form. Field service technicians will instruct you in the operation and servicing of your machine. Following this, the Machine Registration form is to be returned to SIMBA. This confirms your formal acceptance of the machine. The warranty period begins on the date of delivery.



We reserve the right to alter illustrations as well as technical data and weights contained in these Operating Instructions for the purpose of improving the component.

### Warranty Guidelines

1. The period of liability for material defects (warranty) relating to our products is 12 months. In the case of written deviations from the statutory provisions, these agreements shall apply.

They shall become effective upon installation of the machine with the end customer. All wear parts are excluded from the warranty.

2. Warranty claims must be submitted to the SIMBA Customer Service Department in Sleaford via your dealer. It is only possible to process claims which have been correctly completed and submitted no later than 14 days after the date of repair.

3. In the case of deliveries made under the warranty which are subject to the return of the old parts, the old parts must be returned to SIMBA within 28 days after the damage occurred.

4. In the case of deliveries made under the warranty which are not subject to the return of the old parts, these parts must be kept for the purpose of further decisions for a period of 3 months after receipt of the warranty claim.

5. Warranty repairs to be carried out by outside companies, or repairs which are expected to take more than 10 working hours, must be agreed upon in advance with the Customer Service Department.

# 1. Safety Data

The following warnings and safety instructions apply to all sections of these Operating Instructions. All safety instructions for the machine should be followed.

## 1.1 Operating Instructions:

The Operating Instructions distinguish between three different types of warning and safety instructions. The following graphic symbols are used:



Important!



Risk of injury!



Risk of fatal and serious injuries!

It is important that all the safety instructions contained in these Operating Instructions and all the warning signs on the machine are read carefully.

Ensure that the warning signs are legible. Replace any signs that are missing or damaged.

These instructions must be followed in order to prevent accidents. Inform other users of the warnings and safety instructions.

Do not carry out any operations which may affect safe use of the machine.

## 1.2 Use for the Intended Purpose

The SIMBA Series 1 Toolbar is built using the latest technology and in accordance with the relevant recognised safety regulations. However, risks of injury for the operator or third parties and impairment of the machine or other tangible assets can arise during use.

The Toolbar unit is only to be operated when in a technically perfect condition and for the intended purpose, taking into consideration safety and risks and following the Operating Instructions. In particular, faults that can impair safety are to be remedied immediately.

Original parts and accessories from SIMBA have been specially designed for this unit. Spare parts and accessories not supplied by us have not been tested or authorised. Installation or use of non-original SIMBA products may have a detrimental effect on specific design features of the unit and affect the safety of machine operators. SIMBA will accept no liability for damage resulting from the use of non-original parts or accessories.

The SIMBA Series 1 Toolbar is designed solely as a Toolbar unit. Use for any other purpose, e.g., as a means of transport, will be deemed to be improper use. SIMBA will accept no liability for damage resulting from improper use. The risk will be borne solely by the operator.

## 1.3 Operational Safety

All protective and safety equipment, such as removable protective equipment, must be in place and functioning reliably before the machine is put in use.



Check screws and bolts regularly for tightness and retighten if necessary.



In the event of malfunctions, stop and secure the machine immediately.



Ensure that any faults are remedied immediately.

## 1.4 No Liability for Consequential Damage

The Series 1 Toolbar has been manufactured by SIMBA with great care. However, problems may still occur when it is used for the intended purpose. This may include:

- Worn wearing parts.
- Damage caused by external factors.
- Incorrect driving speeds.
- Incorrect setting of the unit (incorrect attachment, non-adherence to the Setting instructions).



Therefore, it is crucial to always check your Toolbar unit before and during operation for correct operation and adequate application accuracy.

Compensation claims for damage which has not occurred to the component is excluded. This includes any consequential damage resulting from incorrect operation.

## 1.5 Changing Equipment

- Use suitable supports to secure any raised frame sections suspended above you!
- Caution! Risk of injury due to projecting parts!

## 1.6 During Operation

The person in charge must:

- provide the operator with a copy of the Operating Instructions.
- ensure that the operator has read and understood the instructions.

## 1.7 Servicing & Maintenance

Ensure that regular checks and inspections are always carried out within the periods required by law or specified in these Operating Instructions.

Prior to performing maintenance and servicing work, ensure that the machine is positioned on solid, level ground and is secure and stable.

Before cleaning the unit with water, steam jets (high-pressure cleaning apparatus) or other cleaning agents, cover all openings into which, for reasons of safety or operation, no water, steam or cleaning agents are to penetrate.

When carrying out servicing and maintenance work, retighten any loose screw connections.

## 2. Transportation and Installation

Transportation and initial installation of the machine are described in this chapter.

### 2.1 Delivery

The Toolbar unit is normally delivered, fully assembled, on a (low-bed) truck.

The machine can be lifted off with a crane, fork-lift truck, or other suitable lifting equipment.

When doing so, the weight, the centre of gravity and the attachment points on the unit are to be taken into account.

Depending on the lifting gear, attachment is only to be at appropriate points on the frame.

### 2.2 Transportation

The Series 1 Toolbar can be transported on public roads by hitching it up to a tractor or on a low-bed truck.

The Series 1 Toolbar unit must be lifted clear of the ground for road transport when transported behind a tractor.

- It is important to observe the permitted dimensions and weights when transporting the machine.
- Use suitable lifting gear, e.g. a fork-lift truck.
- If the machine is transported on a trailer or a flat-bed truck, it must be secured using straps or other devices.
- Before transporting the machine on public roads, it must be adjusted to its transportation position and the stipulations relating to road transportation fulfilled.
- The maximum permissible speed is 25 km /h.

### 2.3 Installation

When carrying out installation and maintenance work there is a higher risk of injury. It is important that you familiarise yourself with the component and read the Operating Instructions beforehand.

### 2.4 Hitching-up the machine



When hitching-up the machine, ensure that no-one is between the tractor and the machine.

- Attach the machine to the tractor 3 point linkage.

### 3. Adjustment/Operation

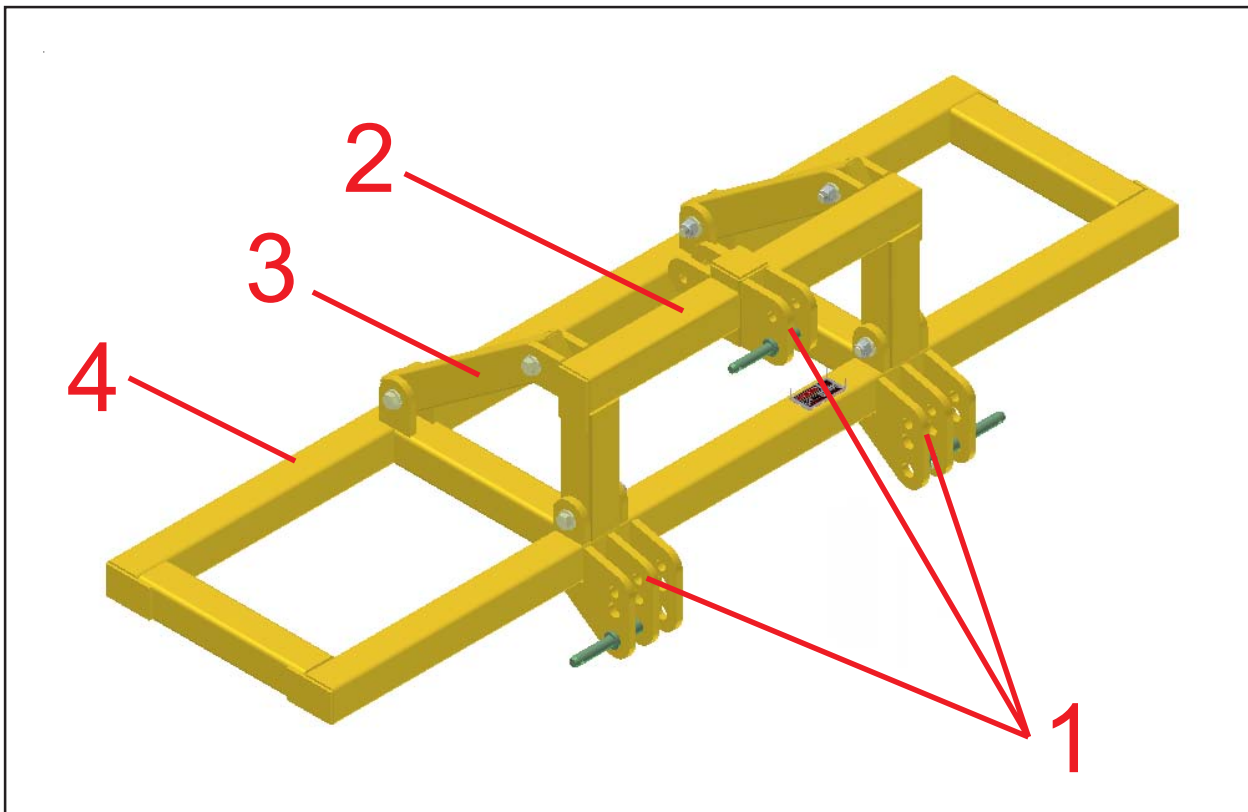

Fig. 3.01: Series 1 Toolbar Frame

#### 3.1 Description

1. 3 Point Linkage (Cat 2/3)
2. Headstock
3. Headstock Brace
4. Mainframe

The SIMBA Series 1 Toolbar is designed to have numerous cultivation applications in diverse crops such as sugar cane, oil seeds, cotton and cereals.

Working elements comprise various tine and disc based combinations in order to suit customers' specific requirements.

Series 1 Toolbars have standard Cat 2/3 linkages in keeping with their universal adaptability.

## 3.2 Working Elements

### 3.2.1 Tines

A wide variety of tines and points are available for the Series 1 Toolbar.

#### 'C' Leaf Tines

C leaf tines can be fitted with either reversible points or, more commonly, clip-on sweep points and are ideal for loosening the soil surface.

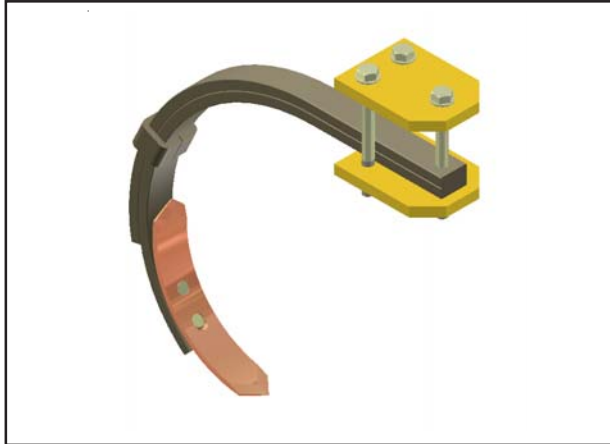

Fig. 3.02: C Leaf Tine

#### Clip-on Sweep Points (for 'C' Leaf Tines)



Fig. 3.03: Clip-on Sweep Point

The clip-on points are attached to the tine with a quick release mechanism. A wedge shaped bracket is bolted on to the tine and a hammer is used to force the coultter on/off the taper using the removal tool provided to disengage the quick release system.

The quick release mechanism makes it possible to change the points quickly and easily without having to use any other tools. The quick release system consists of a wedge, plunger and a rubber spring.

#### Pigtail Tines

Pigtail tines can be fitted with reversible points and are ideal for loosening the soil surface.

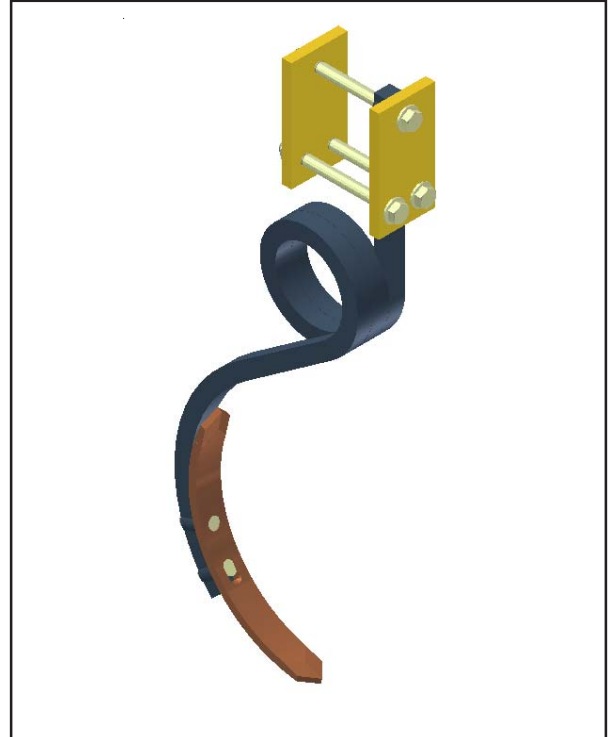

Fig. 3.04: Vertical Pigtail Tine

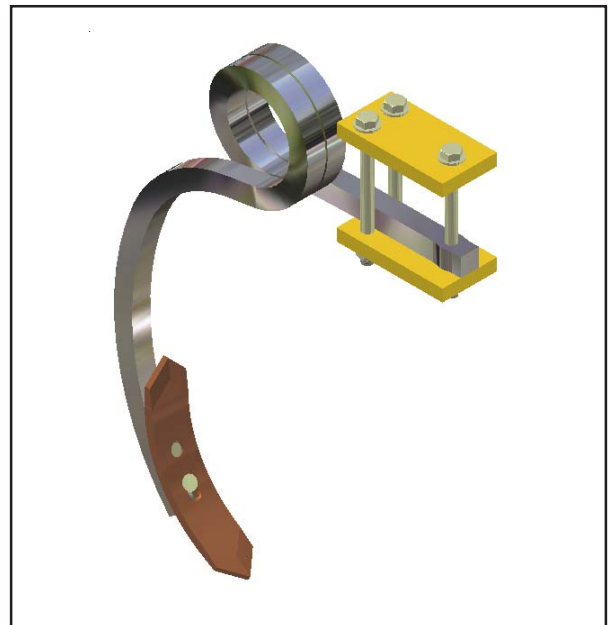

Fig. 3.05: Horizontal Pigtail Tine

## Subsoiler (Pro-Lift) Tines

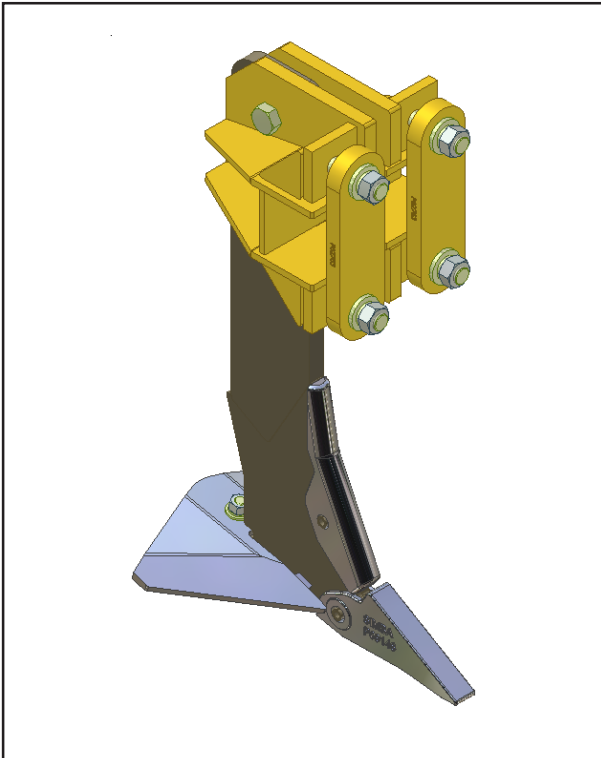

Fig. 3.06: Pro-Lift Tine

Different wings are available to suit the soil conditions and optimise the performance of the machine when using subsoiler tines.

Tine depth is achieved by moving the tines up and down in the adjustable clamps.

### Pro-Lift Wings



**Standard Wing**  
**P09060**

- Maximum soil disturbance with minimum draft requirement under normal circumstances.
- Wing angle reduces wear rates on leg.

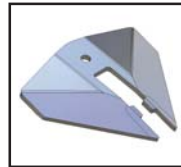

**Extra Lift Wing**  
**P10392**

- Increased lift height and rake angle creates greater soil disturbance on all soil types especially in moister conditions.
- Lower relative distance between edge of wing and point reduces draft requirement.
- Has ability to work at lower depths with no decrease in soil disturbance or risk of smear.

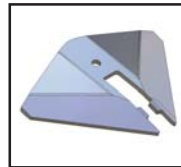

**Extra Wide Wing**  
**P10411**

- Improved lateral shatter in moist/wet soils, or non-cohesive soils.
- Ideal for deep vegetable applications under light/medium soils.



**Wear Shroud**  
**P11181**

- Wear plate to take soil abrasion so lower trailing edge of tine does not wear.

### Furrower Tines

Furrower tines create ridges in the soil ideal for root crop applications such as potatoes.

### 3.2.2 Disc Ridger

Disc ridgers are designed to leave a ridge in the soil. The disc ridger units are usually mounted onto the frame in pairs about row centres however are not limited to this configuration.

The rotation and angle of the disc ridger units are altered using bolts positioned in the holes located at points A and B in the diagram below. Increasing the rotation (A) will increase the ridge height. Increasing the disc angle (B) will increase the cutting and lifting effect on the soil.

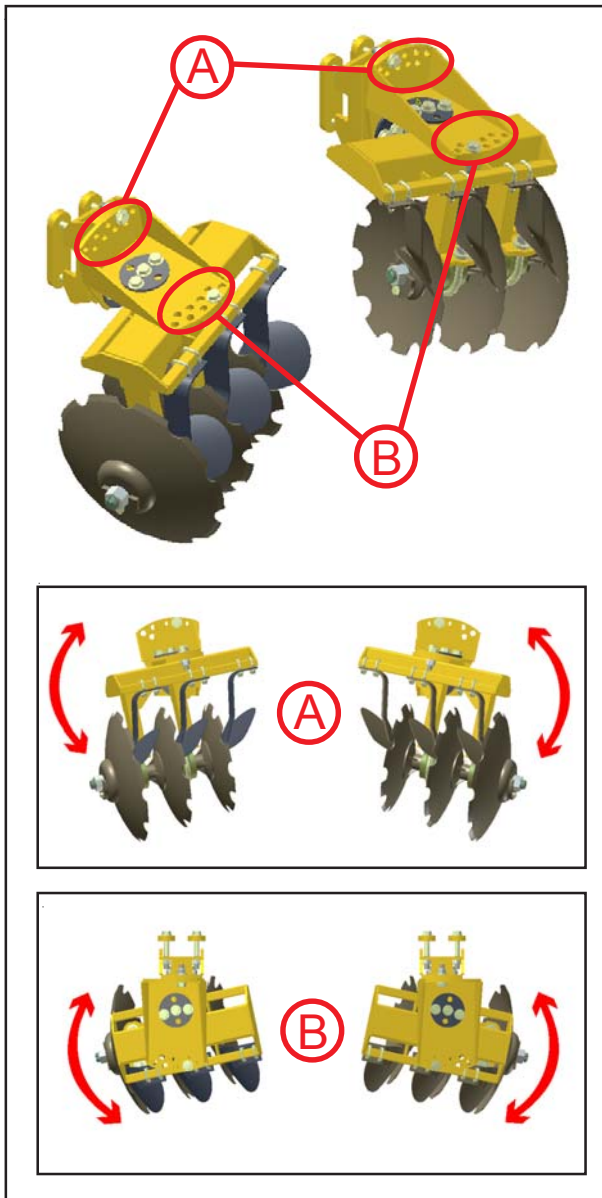

Fig. 3.07: Disc Ridger Adjustment

### 3.2.3 Depth Wheels

Two different types of depth wheels are available to regulate the depth of the machine in work. These wheels are adjusted using either a topline adjuster or a jack (depending on which units are fitted).

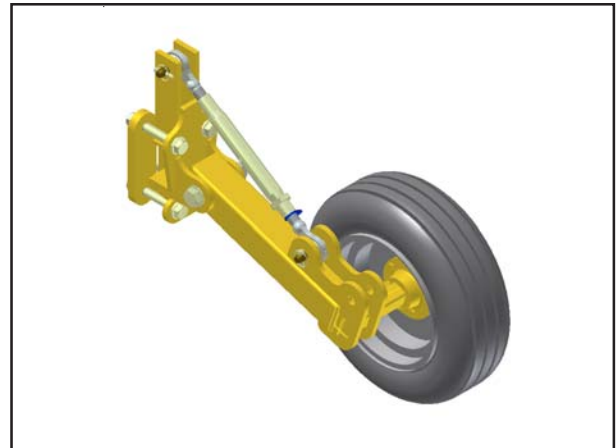

Fig. 3.08: Depth Wheel (Toplink Adjuster Type)

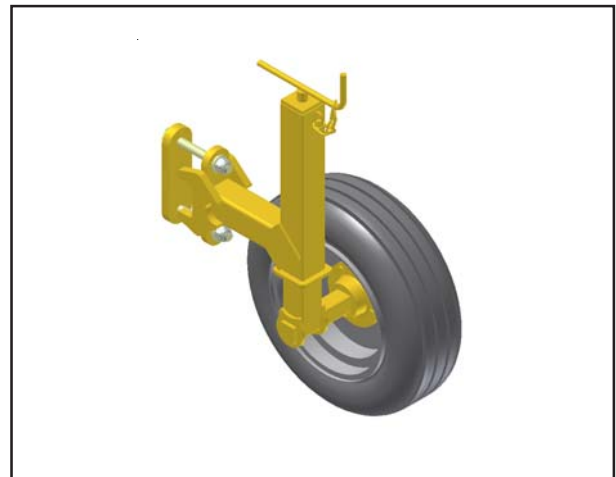

Fig. 3.09: Depth Wheel (Jack Type)

### 3.3 Work Instructions

Turning:



Before turning, the machine should be eased out of work while driving. Likewise, it should be eased back into work once the turn has been completed.

### 3.4 Checks

The working quality depends on the adjustments and checks made prior to and during work, as well as on regular servicing and maintenance of the component.

Before beginning work it is therefore important to carry out any necessary servicing required.

### Working Elements

- Are the working elements in good working order?

### 3.5 Parking

The machine should be parked on a firm, level surface resting on its working elements. In cases where this is not possible the machine must be left in a stable, supported position.

## 4. Servicing and Maintenance



Follow the safety instructions for servicing and maintenance.

### 4.1 Servicing

Your Series 1 Toolbar unit has been designed and constructed for maximum performance, operational efficiency and operator friendliness under a wide variety of operating conditions.

Prior to delivery, your Toolbar unit has been checked at the factory and by your authorised dealer to ensure that you receive it in optimum condition.

To ensure trouble-free operation, it is important that servicing and maintenance work is performed at the recommended intervals.



When changing points on tines extreme care should be taken. Wear goggles at all times when changing tine points.

### 4.2 Cleaning

In order to ensure that the Toolbar is always in operating condition and to achieve optimum performance, perform the cleaning and servicing work at regular intervals.

### 4.3 Storage / Parking

In order to avoid damage as a result of moisture, the machine should be parked, if possible, indoors or under cover.

### 4.4 Operator Support

If you have a problem, please contact Your dealer. They will endeavour to solve any problems which may occur and provide you with support at all times.

In order to enable your dealer to deal with problems as quickly as possible, it helps if you can provide them with the following data. Always state the:

- Customer Number
- Name and Address
- Machine Model
- Serial Number
- Date of Purchase and Operating Hours
- Type of Problem

### 4.5 Maintenance Intervals

Apart from daily maintenance, the maintenance intervals are based on the number of operating hours and time data.



Keep a record of your operating hours to ensure that the specified maintenance intervals are adhered to as closely as possible.



Never use a Series 1 Toolbar unit that is due for maintenance. Ensure that all deficiencies found during regular checks are remedied immediately.



Place the machine on suitable supports when working underneath! Do not work under a machine which is not supported!

On a new machine tighten all nuts and bolts after 5 hours work and again after 15 hours. This also applies to parts that have been moved or replaced. After the initial 15 hours of work a once a week check should be sufficient depending on daily work rates.

## 4.6 Maintenance Overview

Series 1 Toolbar Maintenance Overview			
	Instructions	Interval	Note
<b>After first operation</b>			
Check all screw, bolt and plug connections	Check they are firmly seated. Tighten / Secure if necessary - Refer to table below for bolt torques	---	---
Check wheel studs for tightness	Check on delivery and before transporting the machine	---	---
Lubricate machine	See overview of lubricating points	---	Page 19
<b>During operation</b>			
Lubricate machine	See overview of lubricating points	---	Page 19
Depth Wheel studs	Check tightness before use	daily	---
Disc Ridger Axles	Check condition, tightness, mountings and smooth operation	daily	Page 15
Tines	Check setting and ensure implements are firmly secured	daily	Page 13
Toplink Adjusters	Check setting and ensure they are firmly secured	daily	---
Working Depth	Check setting and ensure implements are firmly secured	daily	---
<b>After season</b>			
Lubricate machine	See overview of lubricating points	---	Page 19
Bolts / Lock Bolts / Toplink adjusters	Grease any exposed threads	---	---
Entire machine	Carry out cleaning and maintenance	---	---

Max. Bolt Torques	
M12 8.8	10 KgM ( 73 lb.ft)
M16 8.8	24 KgM ( 176 lb.ft)
M20 8.8	47 KgM ( 345 lb.ft)
M24 8.8	80 KgM ( 587 lb.ft)
M30 8.8	150 KgM ( 1100 lb.ft)
M36 8.8	280 KgM ( 2055 lb.ft)
5/8" UNC	24 KgM ( 175 lb.ft)

## 4.7 Overview of Lubricating Points

Series 1 Toolbar lubrication points	Interval	Diag. No.
Disc Ridger Axles	10 Hours	4.01
Depth Wheel Hubs (remove hub caps and pack with grease)	End of Season	4.02

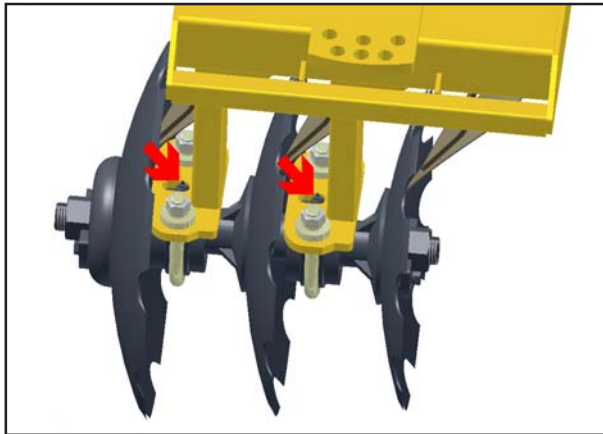

Fig. 4.01: Disc Ridger Axle Grease Points

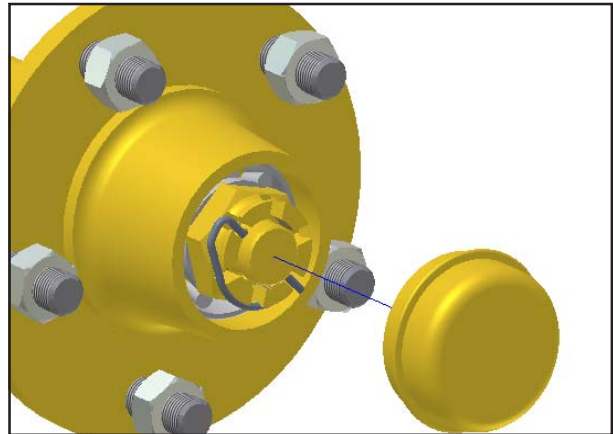

Fig. 4.02: Depth Wheel Hubs

### Lubricants

All lubricating points on the machine can be lubricated with multigrade lubricating grease as specified in DIN 51825 KP/2K - 40.

