

4-7M CUB SERIES TANDEM

DISC HARROW

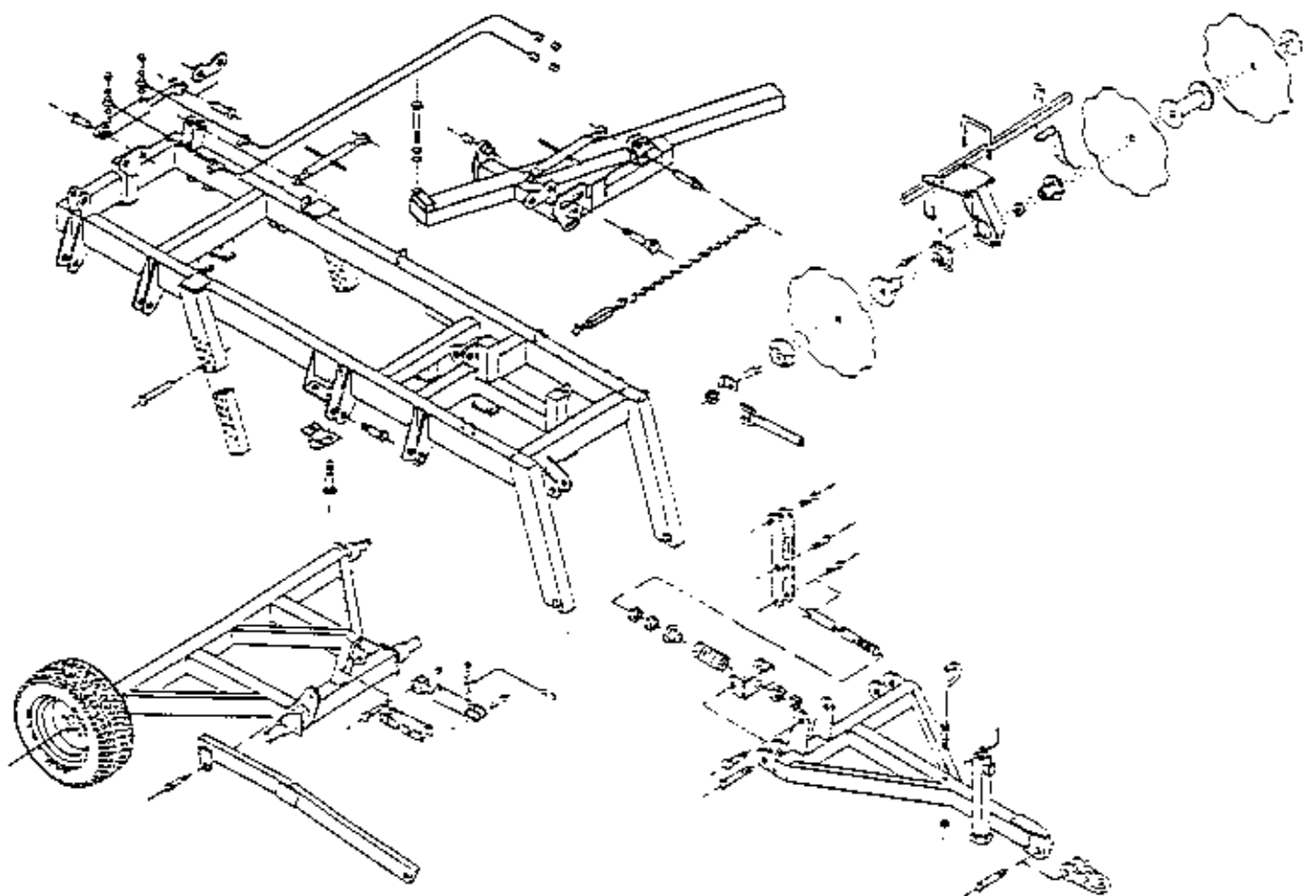

OPERATORS MANUAL
&
SPARE PARTS BOOK

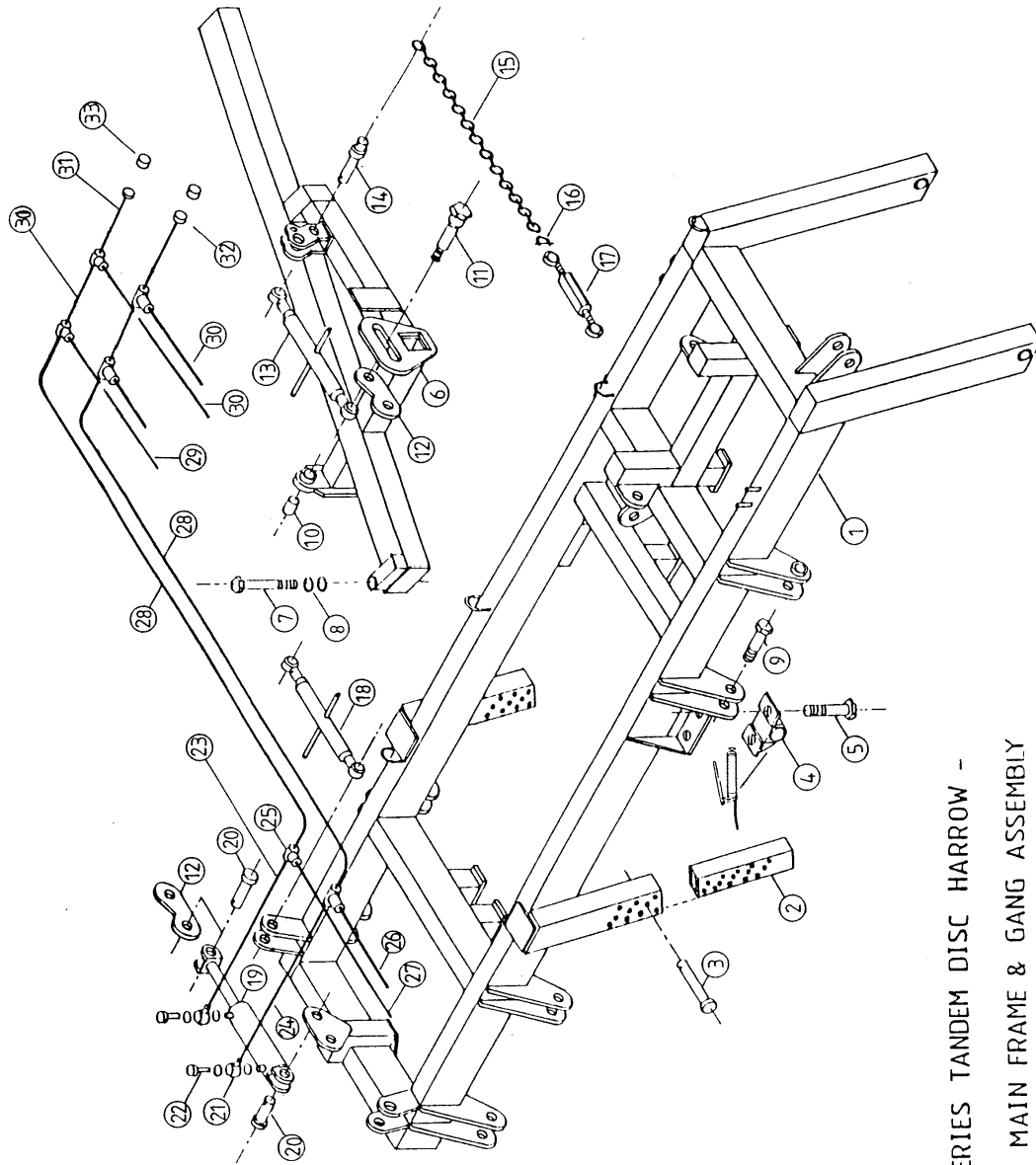

4-7M. CUB SERIES TANDEM DISC HARROW -
MAIN FRAME & GANG ASSEMBLY

4-7M CUB SERIES DISC HARROW

MAIN FRAME AND GANG CARRIER ASSEMBLY

<u>ITEM NO.</u>	<u>PT.NO.</u>	<u>DESCRIPTION</u>
1	1976	MAIN FRAME
	1645	WHEEL CYLINDER RAM POINT BUSH
2	1977	INNER DEPTH CONTROL BOX
3	1071	DEPTH CONTROL PIN 25 x 130mm (LYNCH PIN 2484)
4	0068	PLUMMER BLOCK
5	0014	PLUMMER BLOCK BOLT M24 (F/WASHER 2604, S/WASHER 2593, NUT 0717)
6	1978	FRONT L/H GANG CARRIER
	1979	FRONT R/H GANG CARRIER (N.I.)
	1980	REAR L/H GANG CARRIER (N.I.)
	1981	REAR R/H GANG CARRIER (N.I.)
7	0014	GANG STOP BOLT M24 (F/WASHER 2604, NUT 2010)
8	2604	SPACER WASHER M24
9	2725	BALL END PIVOT BOLT M24 (F/WASHER 2604, NUT 2010)
10	1983	BALL END BUSH
11	1985	ANGLE ADJUSTMENT BOLT (MACHINED)
12	1986	CYLINDER PIVOTING LINK
13	0157	TOPLINK CAT 2 15"
14	2834	TRANSPORT PIN 25 x 115/55mm
15	1999	WING TRANSPORT CHAIN
16	2397	'D' SHACKLE
17	1040	CHAIN TENSIONER
18	0158	TOPLINK CAT 2 19"
19	1913	HYDRAULIC CYLINDER 75 x 250 D/A
	1914	HYDRAULIC CYLINDER SEAL KIT 75 x 250 D/A
20	1274	CYLINDER PIN 25 x 115mm
21	0200	1/2" BSP BANJO BLOCK
	2263	1/2" BSP BONDED WASHER
22	0724B	1/2" BSP RESTRICTED BANJO BOLT
23	0176	2FT HYDRAULIC HOSE
24	0177	3FT HYDRAULIC HOSE
25	0204	1/2" BSP 'T' CONNECTOR
26	0177	3FT HYDRAULIC HOSE
27	0178	4FT HYDRAULIC HOSE
28	0183	9FT HYDRAULIC HOSE
29	0177	3FT HYDRAULIC HOSE
30	0176	2FT HYDRAULIC HOSE
31	0186	12FT HYDRAULIC HOSE
32	0203	MALE - MALE ADAPTOR
33	0205	MALE QUICK RELEASE COUPLING

WHEN ORDERING SPARE PARTS PLEASE QUOTE PART NUMBER, MODEL AND SERIAL NUMBER OF MACHINE.

4-7M CUB SERIES DISC HARROW

DRAWBAR ASSEMBLY

<u>ITEM NO.</u>	<u>PT.NO.</u>	<u>DESCRIPTION</u>
1	1987	DRAWBAR
2	3666B	SHACKLE TYPE Q
3	0983	SHACKLE BOLT M30 (F/WASHER 2608, NUT 2011)
4	0305	HOSE MAST M24 (F/WASHER 2604, NUT 0717)
5	0883	DRAWBAR/MAIN FRAME GREASABLE BOLT M30 (F/WASHER 2608, NUT 2011)
6	4025	BRACKET BOLT M24 (F/WASHER 2604, NUT 2010)
7	4121	TENSION BAR BRACKET
8	4122	TENSION BAR BRACKET PIVOT BUSH
9	0320	TENSION BAR
10	0248	TENSION BAR NUT 1 3/4" BSW
11	0316	TENSION BAR COLLAR
12	0322	TENSION BAR SPRING
13	1989	TIE BAR PIVOT
14	1988	GREASABLE BOLT M24 (F/WASHER 2604, NUT 2010)
15	1885	GREASABLE BOLT M30 (F/WASHER 2608, NUT 2011)
16	0071	GREASE NIPPLE
17	0924	TENSION BAR NUT SPANNER 1 3/4" BSW
18	1731	DISC AXLE NUT SPANNER M30
19	1990	DISC AXLE SPANNER 30MM SQ.

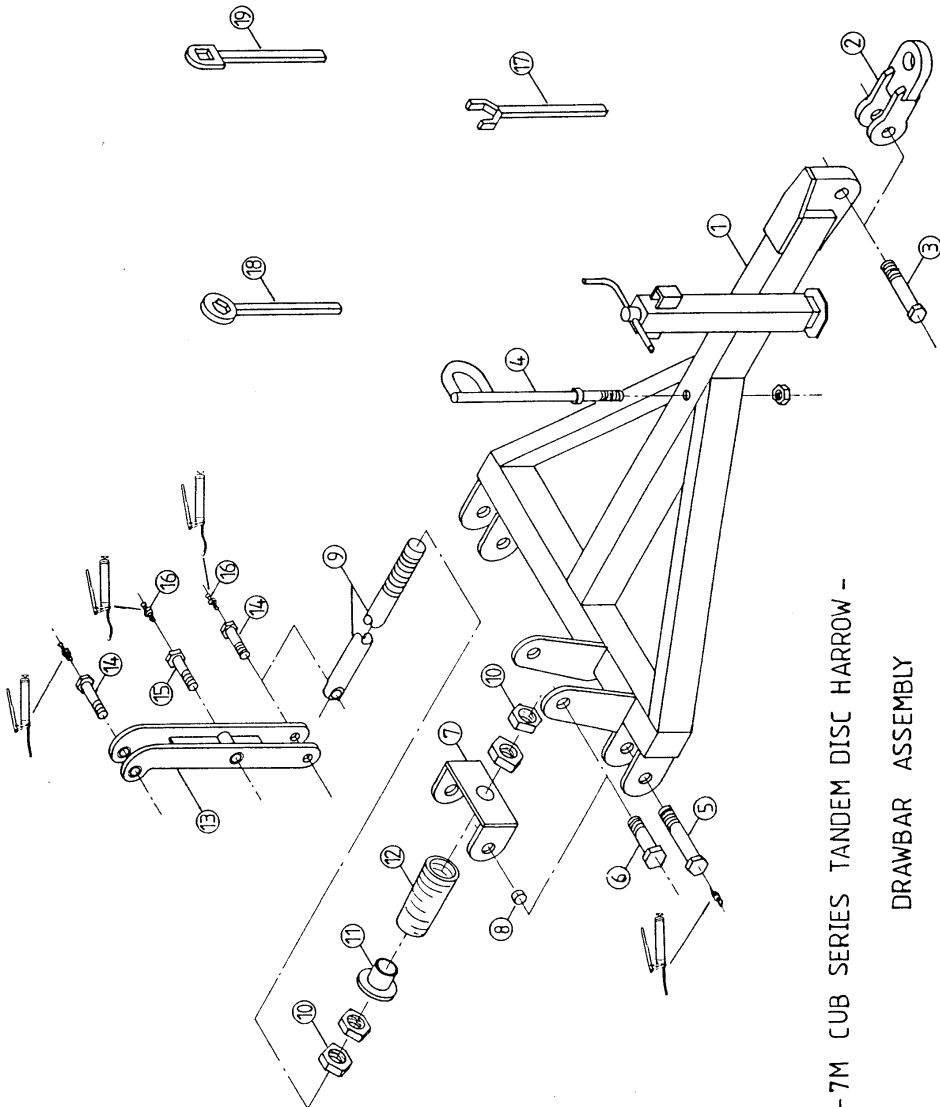

4-7M CUB SERIES TANDEM DISC HARROW -
DRAWBAR ASSEMBLY

WHEN ORDERING SPARE PARTS PLEASE QUOTE PART NUMBER,
MODEL AND SERIAL NUMBER OF MACHINE.

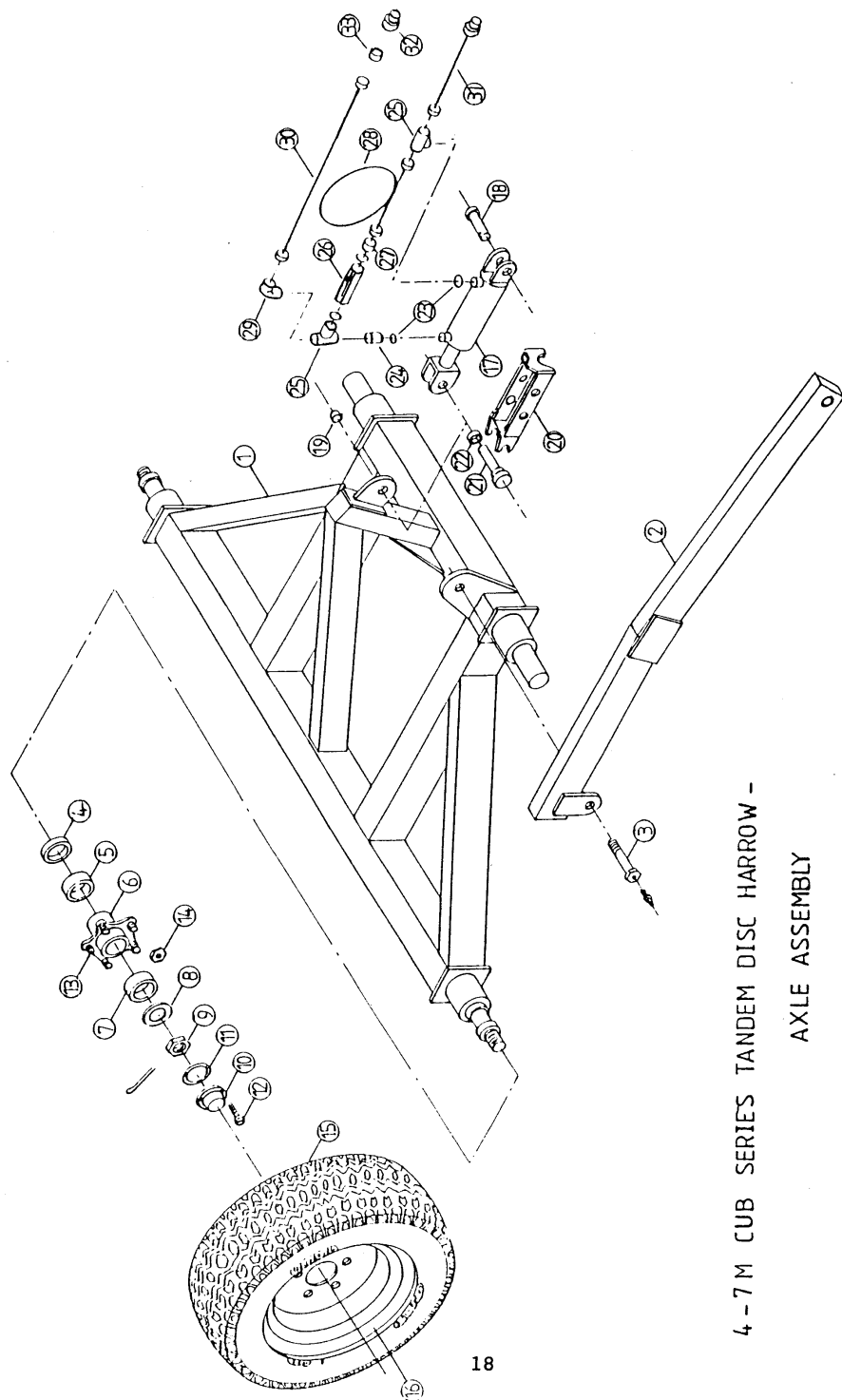

4-7M CUB SERIES DISC HARROW

AXLE ASSEMBLY

ITEM NO.	PT. NO.	DESCRIPTION
1	1996	AXLE FRAME
2	1997	TIE BAR
3	1988	TIE BAR/AXLE GREASABLE BOLT M24 (F/WASHER 2604 NUT 2010)
	0071	GREASE NIPPLE

5 STUD HUB MODELS

4	0439	GREASE SEAL
5	0440	INNER BEARING (CUP AND CONE)
6	0438	HUB CASTING
7	0440	OUTER BEARING (CUP AND CONE)
8	----	NOT APPLICABLE
9	0443	CASTLE NUT
10	0445	HUB CAP
11	0444	HUB CAP GASKET
12	0446	HUB CAP SCREW (3 PER HUB)
13	0707	WHEEL STUD RIGHT HAND
14	0448	WHEEL NUT RIGHT HAND
4-14	0437	5 STUD HUB COMPLETE RIGHT HAND
15	1072	10.0/75-15, 10 PLY TYRE (TUBE 1074)
	0138	11.5/80-15, 10 PLY TYRE (TUBE 0139)
16	0140	5 HOLE RIM TO SUIT 10.0/75-15 & 11.5/80-15

6 STUD HUB MODELS

4	0365	GREASE SEAL
5	0366	INNER BEARING (CUP & CONE)
6	0462	HUB CASTING
7	0367	OUTER BEARING (CUP & CONE)
8	----	NOT APPLICABLE
9	0710	CASTLE NUT
10	0370	HUB CAP
11	0739	HUB CAP GASKET
12	0469	RETAINING BOLT (3 PER HUB)
13	0709	WHEEL STUD RIGHT HAND
14	0471	WHEEL NUT RIGHT HAND
4-14	0641	6 STUD HUB COMPLETE RIGHT HAND
15	0143	12.5/80-15, 14 PLY TYRE (TUBE 0144)
	4128	400/60-15.5, 10 PLY TYRE
16	0146	6 HOLE RIM TO SUIT 12.5/80-15 TYRE
	4128	6 HOLE RIM TO SUIT 400/60-15.5 TYRE

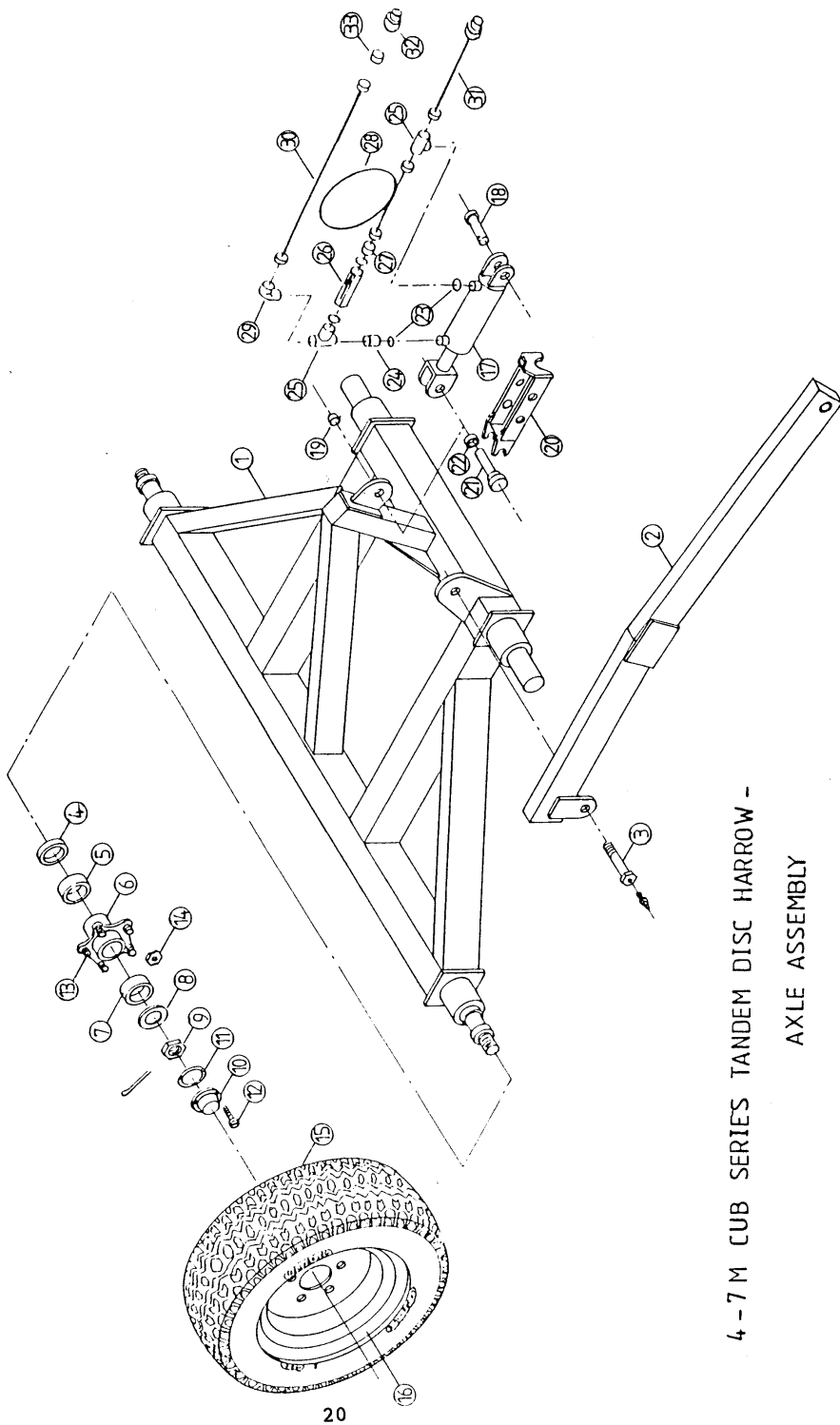

- | | | |
|----|------|-------------------------------------|
| 17 | 0160 | HYDRAULIC CYLINDER 100 X 230 D/A |
| | 0161 | CYLINDER SEAL KIT FOR 100 X 230 D/A |
| 18 | 1274 | CYLINDER PIN 25 X 115mm |
| 19 | 1645 | RAM POINT SPRUNG BUSH |
| 20 | 1147 | TRANSPORT CYLINDER LOCKING COLLAR |
| 21 | 1148 | TRANSPORT LOCKING PIN |
| 22 | 1149 | COLLAR BUSH |
| 23 | 2263 | 1/2" BONDED WASHER |
| 24 | 0206 | MALE - FEMALE ADAPTOR |
| 25 | 0204 | 1/2" BSP 'T' ADAPTOR |
| 26 | 3061 | 300 PSI RELIEF VALVE |
| 27 | 0203 | MALE - MALE ADAPTOR |
| 28 | 0176 | HYDRAULIC HOSE 2ft |
| 29 | 2734 | MALE - FEMALE 90° ELBOW |
| 30 | 0191 | HYDRAULIC HOSE 17ft |
| 31 | 0190 | HYDRAULIC HOSE 16ft |
| 32 | 0205 | MALE QUICK RELEASE COUPLING |
| 33 | 3236 | RESTRICTED MALE - MALE ADAPTOR |

WHEN ORDERING SPARE PARTS PLEASE QUOTE PART NUMBER,
MODEL AND SERIAL NUMBER OF MACHINE.

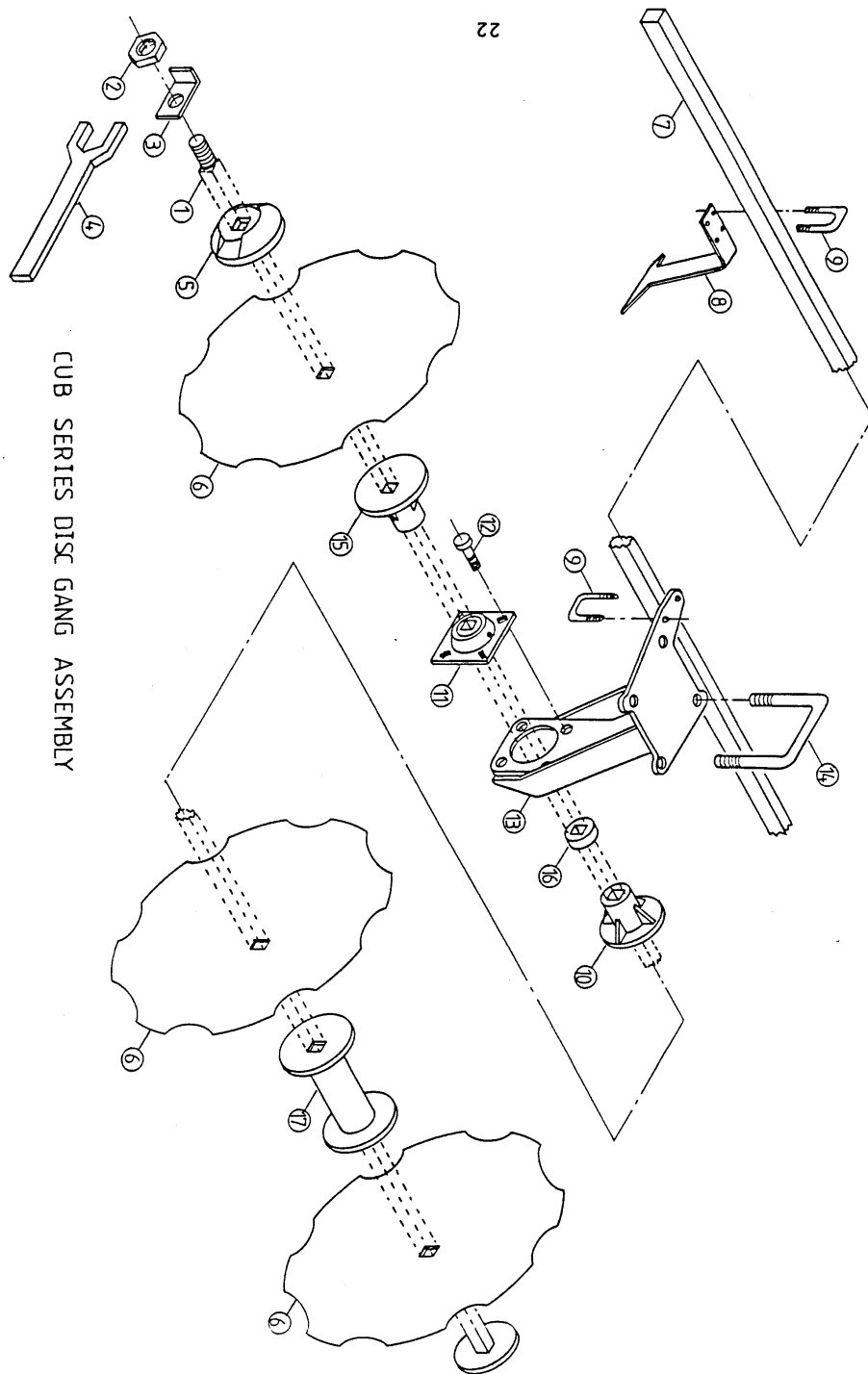

CUB SERIES DISC GANG ASSEMBLY

CUB SERIES DISC GANG ASSEMBLY

ITEM NO.	PT. NO.	DESCRIPTION
1	----	DISC AXLE (SEE BOTTOM OF PAGE)
2	0896	DISC AXLE NUT M30
3	1730	LOCKING TAB
4	1731	DISC AXLE SPANNER
5	1505	AXLE END CONVEX SPACER
6	2782	DISC BLADE 450mm DIA. CUTAWAY
	2783	DISC BLADE 450mm DIA. PLAIN
	2399	DISC BLADE 500mm DIA. CUTAWAY
	2398	DISC BLADE 500mm DIA. PLAIN
	1723	DISC BLADE 550mm DIA. CUTAWAY
	1724	DISC BLADE 550mm DIA. PLAIN
	1726	DISC BLADE 600mm DIA. CUTAWAY
	1727	DISC BLADE 600mm DIA. PLAIN
7	1733	SCRAPER RAIL (STATE LENGTH REQUIRED)
8	3644	SCRAPER L/H
	3645	SCRAPER R/H (N.I.)
9	0002	SCRAPER 'U' BOLT M12 (F/WASHER 2601, NUT 2007)
10	1506	BEARING CONVEX SPACER
11	1486	BEARING
12	1737	BEARING BOLT AND NUT M12 x 30 C.S.K. SQ.
13	1738	BEARING PILLAR L/H
	1739	BEARING PILLAR R/H (N.I.)
14	1619	PILLAR 'U' BOLT M20 (F/WASHER 2603, NUT 2009)
15	1507	CONCAVE SPACER
16	----	N/A
17	1743	STEEL SPOOL - 230mm

CUB SERIES DISC AXLE LENGTHS

DESCRIPTION	AXLE	LENGTH	PT. NO.
4M F.W. CUB (230mm SPACING)	ALL	1965mm	2648
	ALL OUTSIDE	1275mm	2638
5M F.W. CUB (230mm SPACING)	ALL INSIDE	1045mm	2636
	ALL OUTSIDE	1275mm	2638
6M F.W. CUB (230mm SPACING)	ALL INSIDE	1505mm	2641
	ALL OUTSIDE	1735mm	2645
7M F.W. CUB (230mm SPACING)	ALL INSIDE	1505mm	2641

WHEN ORDERING SPARE PARTS PLEASE QUOTE PART NUMBER, MODEL AND SERIAL NUMBER OF MACHINE.



2

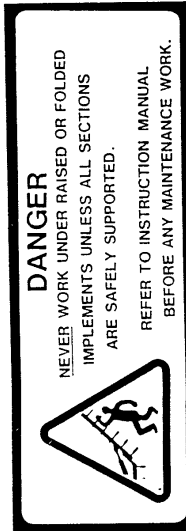

1

CUB SERIES
TANDEM DISC HARROW

3

MAINTENANCE

DAILY SERVICE

- DO NOT GREASE DISC AXLE BEARINGS.
- GREASE TRANSPORT AXLE PLUMMER BLOCKS UNTIL GREASE SHOWS.
- GREASE TENSION BAR MOUNTING BOLT UNTIL GREASE SHOWS.
- GREASE TENSION BAR MOUNTING BOLT UNTIL GREASE SHOWS.
- GREASE TIE BAR TO AXLE BOLT UNTIL GREASE SHOWS.
- GREASE DRAWBAR PIVOT BOLTS UNTIL GREASE SHOWS.
- GREASE SPRINGS.
- CHECK FOR CRACKS OR DAMAGE TO WHEELS FOR DAMAGE TO TYRES.
- CHECK HYDRAULIC CONNECTIONS FOR LEAKS.

WEEKLY SERVICE

- DO NOT GREASE DISC AXLE BEARINGS.
- TIGHTEN ALL NUTS AND BOLTS INCLUDING WHEEL NUTS.
- CHECK ALL DISC AXLES. SEE OPERATORS MANUAL IF LOOSE. IF NECESSARY.
- CHECK TYRE PRESSURES. ADJUST IF NECESSARY.

END OF SEASON SERVICE

SEE OPERATORS MANUAL FOR INSTRUCTIONS

OPERATION

DO NOT TURN WITH MACHINE IN WORK

SIMBA

SIMBA

4



SIMBA

MANUFACTURERS OF
CULTIVATION, LAND
DEVELOPMENT AND EARTH
MOVING EQUIPMENT

BRITISH MADE

Simba Machinery Ltd.

Widdows Road, Banchory, Linnearshire MK32 7FW, England.
Telephone: 01753 811111
Telex: 317518 Simba G

5



6

SIMBA STICKERS

ITEM NO.	PT. NO.	DESCRIPTION
1	2918	* DANGER (RAISED SECTIONS)
2	2912	SIMBA "S" - (SMALL)
	2913	SIMBA "S" - (LARGE)
3	4149	* MAINTENANCE
4	2906	SIMBA - (SMALL)
	2907	SIMBA - (MEDIUM)
	2908	SIMBA - (LARGE)
5	2909	SIMBA ADDRESS
6	2911	UNION JACK (BRITISH MANUFACTURED)

* **IMPORTANT:** ALWAYS REPLACE SAFETY AND MAINTENANCE STICKERS IF WORN.

WHEN ORDERING SPARE PARTS PLEASE QUOTE PART NUMBER, MODEL NUMBER AND SERIAL OF THE MACHINE.