



P12719 04/05/05



**DECLARATION OF CONFORMITY**

Simba International Limited hereby declare that the Product described in this Operators Manual, and defined by the Serial Number Plate attached to the Chassis of the Machine (a part copy of which is detailed overleaf and must be completed indicating the relevant machine details), conforms with the following Directives and Regulations, and has been certified accordingly.

**EC Machinery Directive 89/392/EEC, as amended by 91/3688/EEC, 93/44/EEC, and 93/688/EEC.**

In order to fulfill the requirements of health and safety described in the EC Directive, the following standards and technical specifications have been taken into account:

**EN 292 - 1**  
**EN 292 - 2**

**THE MANUFACTURER**

Simba International Limited  
Woodbridge Road  
SLEAFORD  
NG34 7EW  
Lincolnshire  
NG34 7EW  
England.

Telephone 01529 304654.

**CERTIFIED ON BEHALF OF SIMBA INTERNATIONAL LIMITED.**

Philip J. Wright. BSc (Hons) C Eng. MI Agr.E  
Technical Director.



## **WARRANTY** **TERMS AND CONDITIONS**

In this warranty Simba International Ltd., is referred to as “the Company”.

1. Subject to the provisions of this warranty the Company warrants each new machine sold by it to be sold free from any defect in material or workmanship for a period of 12 months from date of installation with the end-user.

Some specific items have additional warranty over and above the standard 12 months. Details of these can be obtained upon request directly from the distributor or Simba International Ltd.

2. If the machine or part thereof supplied by the Company is not in accordance with the warranty given in clause 1 the Company will at its option:
  - (a) make good the machine or part thereof at the Company's expense, or
  - (b) make an allowance to the purchaser against the purchase price of the machine or part thereof, or
  - (c) accept the return of the machine and at the buyers option either:
    - I) repay or allow the buyer the invoice price of the machine or part thereof, or
    - II) replace the machine or part thereof as is reasonably practical.
3. This warranty shall not oblige the Company to make any payment in respect of loss of profit or other consequential loss or contingent liability of the Purchaser alleged to arise from any defect in the machine or impose any liability on the Company other than that contained in clause 2.
4. Any claim under this warranty must be notified to the Company in writing specifying the matters complained of within 14 days from the date of repair.
5. Any claim under this warranty must be made by the original purchaser of the machine and is not assignable to any third party.
6. If the purchaser hires out the machine to any third party the warranty shall apply only to matters notified to the Company in writing within 90 days of the date of delivery and clause 1 shall be read as if the period of 90 days were substituted for the period of 12 months.
7. The warranty will cease to apply if:
  - (a) any parts not made, supplied or approved in writing by the Company are fitted to the machine or
  - (b) any repair is carried out to the machine other than by or with the express written approval of the Company or
  - (c) any alterations not expressly authorized by the Company in writing are made to the machine or
  - (d) the machine is damaged by accident or
  - (e) the machine is abused or overloaded or used for a purpose or load beyond its design capabilities, or used in conjunction with a tractor whose power output capability exceeds the stated implement power requirement by more than 40%. For the purpose of these terms and conditions, “stated implement power requirement” refers to wheeled tractors unless specifically stated. These power requirements should be reduced by 20% when used in conjunction with tracked tractors.
  - (f) the machine is operated as part of a ‘cultivation train’ where more than one implement is being towed, without the express written approval of Simba International Ltd.
  - (g) any maintenance is not carried out in accordance with the service schedules in the operator's manual.
  - (h) the Installation and Warranty Registration Certificate is not received by Simba International Ltd., Service Dept., Woodbridge Road, Sleaford, Lincolnshire, England, NG34 7EW, within 7 days of installing a new machine.

## Machine Identification

Enter the relevant data in the following list upon acceptance of the machine:

Serial Number	
Type of Machine	
Machine Width	
Year of Construction	
Delivery Date	
First Operation	
Accessories	

Operating Instructions/Spare Parts List: May 2005

Dealer Address:      Name: .....  
                         Street: .....  
                         Place: .....  
                         Tel.: .....

Dealer's Customer No.: .....

SIMBA Address:      SIMBA  
                         Woodbridge Road Ind. Est.  
                         Sleaford  
                         Lincolnshire  
                         NG34 7EW

Tel.:            01529 304654  
Fax:            01529 413468  
E-Mail:        simba.international@simba.co.uk

SIMBA Customer No.: .....



## Table of contents

Machine Identification .....	5	<b>5. Servicing and Maintenance</b>	<b>26</b>
<b>Introduction .....</b>	<b>8</b>	5.1 Servicing .....	26
Foreword .....	8	5.2 Cleaning .....	26
Warranty Guidelines .....	8	5.3 Changing Tine Points and Wings ....	26
<b>1. Safety Data .....</b>	<b>9</b>	5.4 Preparation for Storage .....	27
1.1 Safety Symbols .....	9	5.5 Operator Support .....	27
1.2 Use for the Intended Purpose .....	11	5.6 Maintenance Intervals .....	27
1.3 Operational Safety .....	11	5.7 Maintenance Overview .....	28
1.3.1 No liability for Consequential Damage	11	5.8 Overview of Lubricating Points .....	29
1.4 Traffic Safety .....	12	5.9 Lubricating the Machine .....	30
1.5 Accident Prevention .....	12	5.9.1 Handling of Lubricants .....	30
1.5.1 Hitching-up the Machine .....	12	5.9.2 Hygiene .....	30
1.5.2 Connection of the Hydraulic System	12	5.9.3 Storage and Handling .....	30
1.5.3 Changing Equipment .....	13	5.9.4 Measures in case of injury through oil ..	31
1.5.4 During Operation .....	13	5.9.5 Oil Spills .....	31
1.6 Servicing and Maintenance .....	13	5.9.6 Oil Fires .....	31
1.7 Maintenance Areas .....	14	5.9.7 Waste Oil Disposal .....	31
1.8 Authorised Operators .....	14	5.9.8 Lubricants & Hydraulic Oil .....	31
1.9 Protective Equipment .....	14	5.9.9 Hydraulic System .....	31
<b>2. Transportation/Installation .</b>	<b>15</b>	5.9.10 Lubricants .....	31
2.1 Delivery .....	15	<b>6. Faults and Remedies .....</b>	<b>32</b>
2.2 Transportation .....	15	<b>7. Parts &amp; Assembly .....</b>	<b>33</b>
2.3 Installation .....	15	7.1 Parts & Assembly Contents .....	33
2.5 When Driving on the Road .....	16		
2.5.1 Hitching-up the Machine .....	16		
2.5.1.1 Connecting the Hydraulic System	16		
2.6 Parking the Machine .....	16		
<b>3. Technical Data .....</b>	<b>17</b>		
<b>4. Adjustment/Operation .....</b>	<b>18</b>		
4.1 Description .....	18		
4.1.1 Mounted Machines .....	18		
4.1.2 Trailed Machines .....	19		
4.2 Tines .....	20		
4.3 Pro-Lift Points .....	20		
4.4 Double Disc Roll .....	21		
4.5 DD Light Roll .....	21		
4.6 Scraped Crumbler .....	21		
4.7 Aqueel Roll .....	21		
4.8 Operation .....	22		
4.8.1 Mounted Machine Operation .....	22		
4.8.2 Trailing Kit Operation .....	24		
4.9 Work Instructions .....	25		
4.10 Checks .....	25		

## Introduction

### Foreword

Make sure you have read and follow the Operating Instructions carefully before using the machine. By doing so, you will avoid accidents, reduce repair costs and downtime and increase the reliability and service life of your machine. Pay attention to the safety instructions!

SIMBA will not accept any responsibility for any damage or malfunctions resulting from failure to comply with the Operating Instructions.

These Operating Instructions will assist you in getting to know your machine and in using it correctly for its intended purposes. First, you are given general instructions in handling the machine. This is followed by sections on servicing, maintenance and the action to be taken should a malfunction occur.

These operating instructions are to be read and followed by all persons working on or with the machine, e.g.:

- Operation (including preparation, remedying of faults in the operating sequence and servicing).
- Maintenance (maintenance and inspection)
- Transportation.

Together with the Operating Instructions, you receive a Spare Parts List and a Machine Registration form. Field service technicians will instruct you in the operation and servicing of your machine. Following this, the Machine Registration form is to be returned to SIMBA. This confirms your formal acceptance of the machine. The warranty period begins on the date of delivery.



We reserve the right to alter illustrations as well as technical data and weights contained in these Operating Instructions for the purpose of improving the Flatliner 500.

### Warranty Guidelines

1. The period of liability for material defects (warranty) relating to our products is 12 months. In the case of written deviations from the statutory provisions, these agreements shall apply.

They shall become effective upon installation of the machine with the end customer. All wear parts are excluded from the warranty.

2. Warranty claims must be submitted to the SIMBA Customer Service Department in Sleaford via your dealer. It is only possible to process claims which have been correctly completed and submitted no later than 14 days after the date of repair.

3. In the case of deliveries made under the warranty which are subject to the return of the old parts, the old parts must be returned to SIMBA within 28 days after the damage occurred.

4. In the case of deliveries made under the warranty which are not subject to the return of the old parts, these parts must be kept for the purpose of further decisions for a period of 3 months after receipt of the warranty claim.

5. Warranty repairs to be carried out by outside companies, or repairs which are expected to take more than 10 working hours, must be agreed upon in advance with the Customer Service Department.

# 1. Safety Data

The following warnings and safety instructions apply to all sections of these Operating Instructions.

## 1.1 Safety Symbols

### On the machine



Parts may fly off during operation. Keep a safe distance away from the machine!

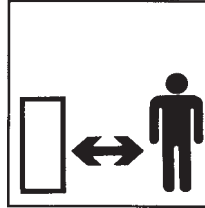

Read and observe the Operating Instructions before starting up the machine!

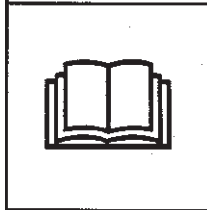

Keep clear of the working range of foldable machine components!

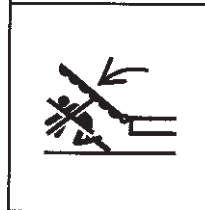

Watch out for escaping pressurised fluids! Follow the instructions in the Operating Instructions!

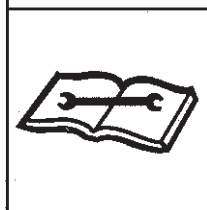

No passengers are allowed on the machine!



Never reach into areas where there is a danger of being crushed by moving parts!

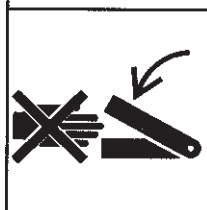

Never reach into any revolving parts!

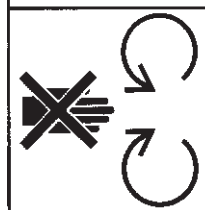



Refer to Operating Instructions before attempting maintenance.

### Operating Instructions:

The Operating Instructions distinguish between three different types of warning and safety instructions. The following graphic symbols are used:



Important!



Risk of injury!



Risk of fatal and serious injuries!

It is important that all the safety instructions contained in these Operating Instructions and all the warning signs on the machine are read carefully.

Ensure that the warning signs are legible. Replace any signs that are missing or damaged.

These instructions must be followed in order to prevent accidents. Inform other users of the warnings and safety instructions.

Do not carry out any operations which may affect safe use of the machine.

## 1.2 Use for the Intended Purpose

The SIMBA Flatliner 500 is built using the latest technology and in accordance with the relevant recognised safety regulations. However, risks of injury for the operator or third parties and impairment of the machine or other tangible assets can arise during use.

The machine is only to be operated when in a technically perfect condition and for the intended purpose, taking into consideration safety and risks and following the Operating Instructions. In particular, faults that can impair safety are to be remedied immediately.



Original parts and accessories from SIMBA have been specially designed for this machine. Spare parts and accessories not supplied by us have not been tested or authorised. Installation or use of non-original SIMBA products may have a detrimental effect on specific design features of the machine and affect the safety of machine operators and the machine itself. SIMBA will accept no liability for damage resulting from the use of non-original parts or accessories.

The SIMBA Flatliner 500 is designed solely as a cultivation implement. Use for any other purpose, e.g., as a means of transport, will be deemed to be improper use. SIMBA will accept no liability for damage resulting from improper use. The risk will be borne solely by the operator.

## 1.3 Operational Safety

The machine is to be put in operation only after instruction has been provided by an employee of the authorised dealer or an employee of SIMBA. The "Machine Registration" form is to be completed and returned to SIMBA.

All protective and safety equipment, such as removable protective equipment, must be in place and functioning reliably before the machine is put in use.

-  Check screws and bolts regularly for tightness and retighten if necessary.
-  In the event of malfunctions, stop and secure the machine immediately.
-  Ensure that any faults are remedied immediately.

### 1.3.1 No Liability for Consequential Damage

The Flatliner 500 has been manufactured by SIMBA with great care. However, problems may still occur when it is used for the intended purpose. This may include:

- Worn wearing parts.
- Damage caused by external factors.
- Incorrect driving speeds.
- Incorrect setting of the unit (incorrect attachment, non-adherence to the Setting instructions).

-  Therefore, it is crucial to always check your machine before and during operation for correct operation and adequate application accuracy.

Compensation claims for damage which has not occurred to the machine is excluded. This includes any consequential damage resulting from incorrect operation.

## 1.4 Road Traffic Safety

When driving on public roads, tracks and areas, it is important to observe the relevant road traffic laws as well as the specific regulations relating to this machine.



Pay attention to the permitted axle loads, tyre carrying capacity, and total weight in order to maintain adequate braking and steerability.



Passengers on the machine are strictly forbidden!

## 1.5 Accident Prevention

In addition to the Operating Instructions, it is important to observe the accident prevention regulations specified by agricultural trade associations.

### 1.5.1 Hitching-up the machine

There is a risk of injury when hitching/unhitching the machine. Observe the following:

- Secure the machine against rolling.
- Take special care when reversing the tractor!
- There is a risk of being crushed between the machine and the tractor!
- Park the machine on firm, level ground.

### 1.5.2 On the Hydraulic System

Do not connect the hydraulic lines to the tractor until both hydraulic systems (machine and tractor) are depressurised.

The hydraulic system and accumulator are pressurised. Check all lines, pipes, and screw connections regularly for leaks and any recognisable external damage.

Only use appropriate aids when checking for leaks. Repair any damage immediately. Spurting oil can cause injuries and fires!

In case of injury, contact a doctor immediately.

The socket and plugs for the hydraulic connections between the tractor and the machine should be colour-coded in order to avoid incorrect use.

### 1.5.3 Changing Equipment

- Secure the machine to prevent it from accidentally rolling away!
- Use suitable supports to secure any raised frame sections suspended above you!
- Caution! Risk of injury due to projecting parts!
- Use the ladders to climb on to the machine.



Never climb on to rotating parts such as the roll unit. These parts may rotate causing you to slip and suffer serious injury!

### 1.5.4 During Operation

Ensure that the working range and the area around the machine are clear (children!) before operating the machine.

Always ensure adequate visibility!

Do not stand on the machine while it is in operation!

Operators must have a valid driving licence in order to drive on public roads. In the operating area, the operator is responsible for third parties.

The person in charge must:

- provide the operator with a copy of the Operating Instructions, and
- ensure that the operator has read and understood the instructions.
- make sure that the operator is aware of the specific regulations relating to the machine when driving on public roads.

## 1.6 Servicing & Maintenance

Ensure that regular checks and inspections are always carried out within the periods required by law or specified in these Operating Instructions.

When carrying out service and maintenance work always:

- switch off the tractor engine and remove the ignition key.
- wait until all the machine parts have stopped moving.
- depressurize the hydraulic system.

Prior to performing maintenance and servicing work, ensure that the machine is positioned on solid, level ground and is secured to prevent it rolling away. Do not use any parts to climb on to the machine unless they are specifically designed for this purpose.

Before cleaning the machine with water, steam jets (high-pressure cleaning apparatus) or other cleaning agents, cover all openings into which, for reasons of safety or operation, no water, steam or cleaning agents are to penetrate (bearings, for instance).

Next, check all hydraulic lines for leaks, loose connections, chafe marks and damage. Remedy any deficiencies immediately!

Lubricate all the lubricating points to force out any trapped water.

When carrying out servicing and maintenance work, retighten any loose screw connections.

## **1.7 Operating Areas**

The operating areas include the 3 point linkage, hydraulic connections and depth adjustment equipment as well as all operating points requiring maintenance.

All operating areas will be specified and described in detail in the following chapters on servicing and maintenance.

Observe all safety regulations included in the Section dealing with Safety, and in the subsequent sections.

## **1.8 Authorised Operators**

Only those persons who have been authorised and instructed by the operator may operate the machine. The operator must be at least 16 years of age.

## **1.9 Protective Equipment**

For operation and maintenance, you require:

- Tight fitting clothing.
- Strong protective gloves (to provide protection against sharp-edged machine components).
- Protective goggles (to stop dirt getting into your eyes).

## 2. Transportation and Installation

Transportation and initial installation of the machine are described in this chapter.

### 2.1 Delivery

The machine is normally delivered, fully assembled, on a (low-bed) truck.

- The machine can be lifted off with a crane, fork-lift truck, or other suitable lifting equipment.

When doing so, the weights (see Technical Data), the centre of gravity and the attachment points on the machine are to be taken into account.

Depending on the lifting gear, attachment is only to be at appropriate points on the frame.

- The machine can be hitched to a tractor and driven off a low-loader.

### 2.2 Transportation

The Flatliner 500 can be transported on public roads by hitching it up to a tractor or on a low-bed truck.

- It is important to observe the permitted dimensions and weights when transporting the machine.
- Use suitable lifting gear, e.g. a fork-lift truck.
- If the machine is transported on a trailer or a flat-bed truck, it must be secured using straps or other devices.
- Before transporting the machine on public roads, it must be adjusted to its transportation position and the stipulations relating to road transportation fulfilled.
- The maximum permissible speed is 25 km /h.

### 2.3 Installation

When carrying out installation and maintenance work there is a higher risk of injury. It is important that you familiarise yourself with the machine and read the Operating Instructions beforehand.

Operator instruction and initial installation of the machine are carried out by our service technicians or authorised distributors.

The machine must not be used in any way beforehand! The machine can only be released for operation after instructions have been provided by our service technicians or authorised distributors.

- If any modules or parts have been removed for transportation, these shall be mounted by our service technicians/authorised dealers before the instruction takes place.
- Check all important screw connections!
- Lubricate all nipples and joints!
- Check all hydraulic connections and lines (if applicable) for damage.

## 2.5 When driving on the road

When driving on the road the machine must be converted to the transportation position.



There is a risk of injury on specially sharpened edges and when making adjustments on the machine.

- Couple the machine to the tractor.
- Hook up the hydraulics.



When driving on the road, raise the machine completely to prevent the working elements dragging on the ground.

### 2.5.1 Hitching-up the machine



When hitching-up the machine, ensure that no-one is between the tractor and the machine.

- Attach the machine to the tractor 3 point linkage.
- Place the parking stand (if applicable) into the transportation position.

### Connecting the Hydraulic System (on trailed machines)



Connect the hydraulic system only when the hydraulic couplings are depressurised.

## 2.6 Parking the machine

In order to avoid damage as a result of moisture, the machine should be parked, if possible, indoors or under cover.



When manoeuvring the machine, pay attention to your surroundings. Ensure that nobody is in the manoeuvring area (watch for children!).

### Mounted Machines

- Park the machine on level and solid ground. Lower the parking stands (if fitted) to the desired height.
- Lower the machine so that it is supported on the tines and parking stands.
- Unhitch the machine.

The parking stands have 4 height settings:

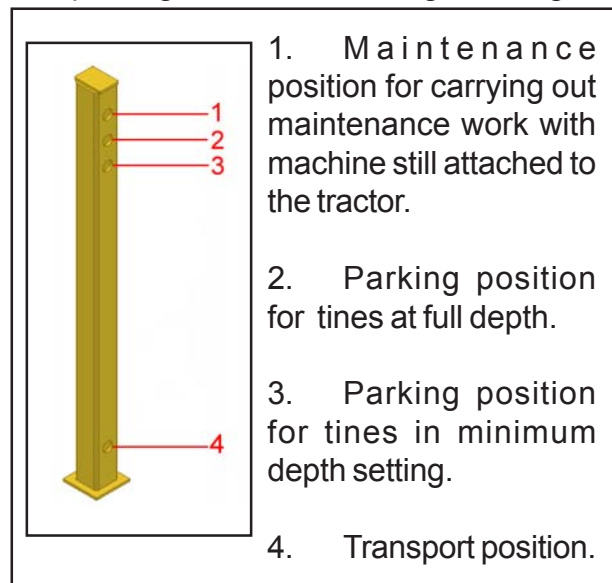

Fig. 2.01: Parking Stand Settings

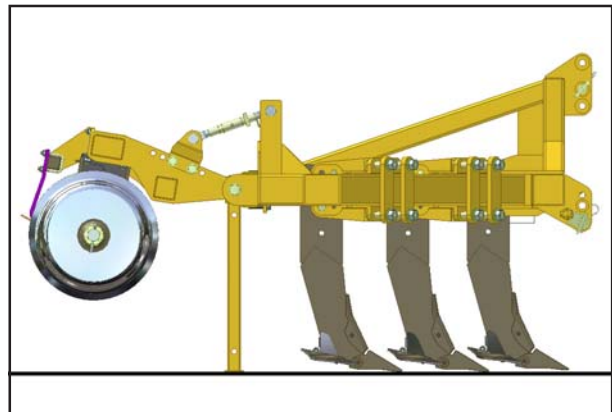

Fig. 2.02: Parking Position

### Trailed Machines

- Park the machine on level and solid ground. Lower the machine so that it is supported.
- Disconnect hydraulic lines from the tractor.
- Unhitch the machine.

## 3. Technical Data

### Flatliner 500

	3m	3.5m	3.8m	4.2m	Trailing Kit
<b>Transport Width</b>	2930mm	3465mm	3935mm	4245mm	-
<b>Working Width</b>	2610mm	3150mm	3615mm	3930mm	-
<b>Length</b>	2500mm	2660mm	2850mm	2950mm	+2940mm
<b>Weight</b>	1730kg	2250kg	2435kg	2760kg	+1080kg
<b>No. of Tines / Tine Spacing</b>	3 / 812	5 / 630	5 / 720	7 / 550	-
<b>Tractor Power Required (H.P.)*</b>	130/150	140/200	140/200	190/260	-

\* It is important to correctly match your implement to your tractor for optimum performance. Two power ratings are listed above. The lower HP figure relates to tracked tractors, the higher HP figure relates to wheeled tractors. In instances where a trailing kit is fitted to the implement the lower figure should be used.

## 4. Adjustment/Operation

### 4.1 Description

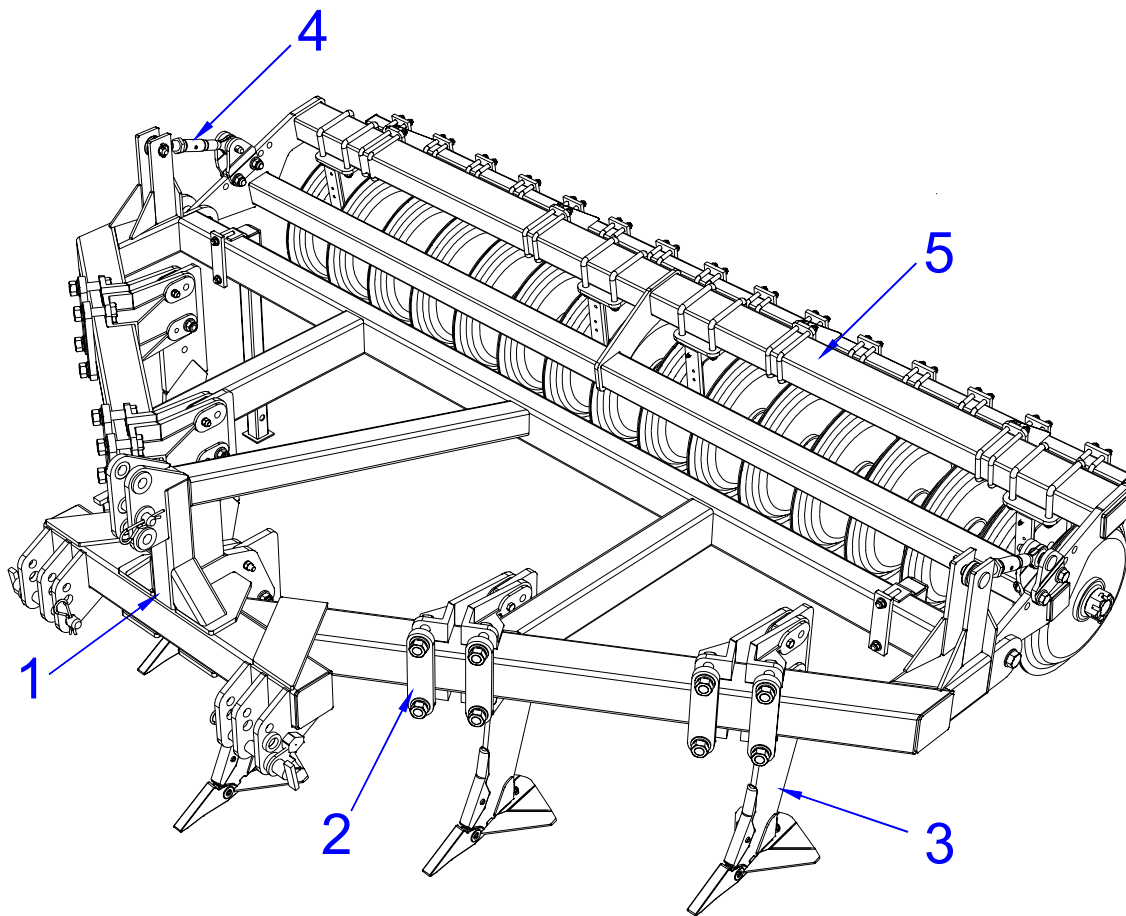

Fig. 4.01: Flatliner 500 (with Double Disc roll)

#### 4.1.1 Mounted Machine

1. 3 Point Linkage Mainframe
2. Adjustable Tine Clamps
3. Pro-Lift Tines
4. Roll Adjusters
5. Rear Roll Unit

The SIMBA Flatliner 500 is a heavy duty 'V' framed subsoiler designed to operate at depths of 300-500mm. Adjustable tine clamps offer flexibility of spacing to provide optimum shatter. Depth control is achieved using the rear roll, ensuring maximum consolidation.

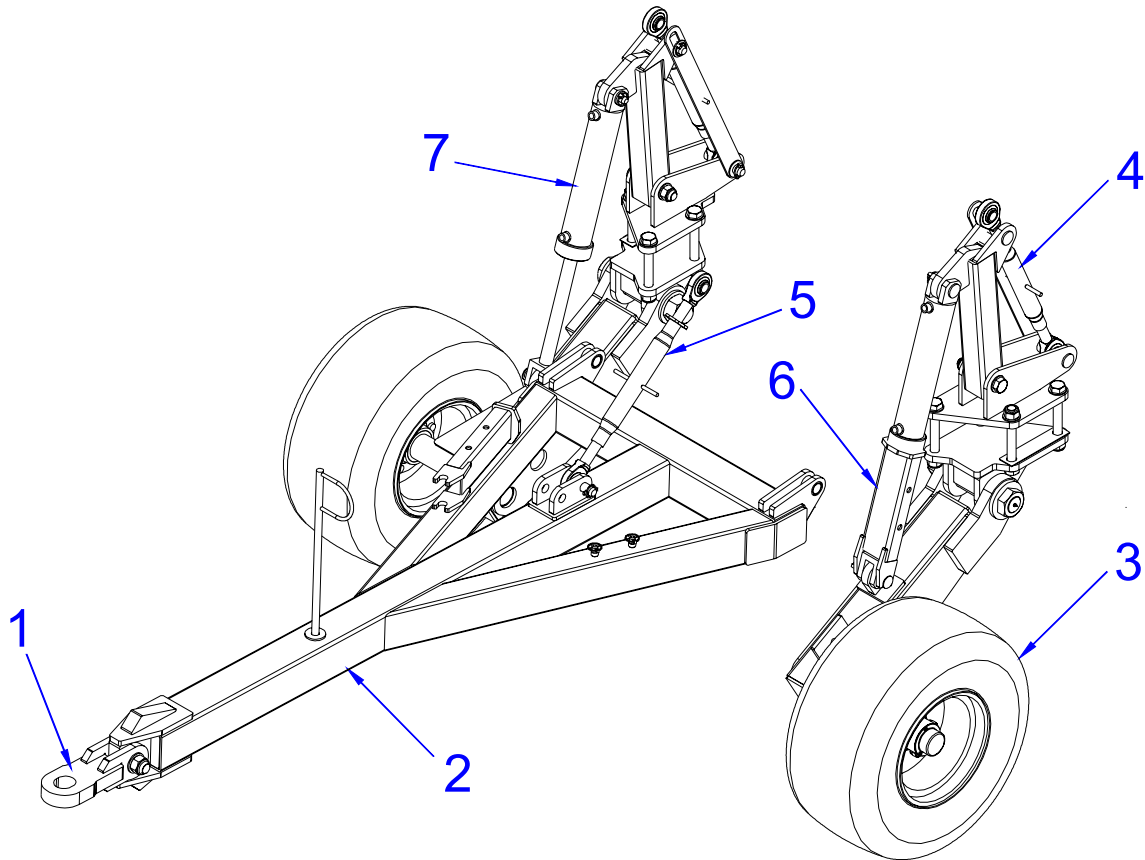

Fig. 4.02: Flatliner 500 Trailing Kit

### 4.1.2 Trailing Kit

1. Hitch
2. Drawbar
3. Transport Wheels
4. Toplink (wheel adjustment)
5. Toplink (pitch adjustment)
6. Transport Lock
7. Hydraulic Cylinder

With the Flatliner fitted with this kit the implement becomes a trailed machine in its own right. The wheel units as provided in the kit are used both for depth control and for road transport. When in road transport the machine is lifted clear of the ground using a hydraulic cylinder on each wheel unit.

For depth control in work, each wheel is set via topline adjusters to the required working depth. When in work the hydraulic cylinder on each wheel is used in the fully closed position. If the wheel units are used in conjunction with a rear mounted roll unit, the wheels may be adjusted to run clear of the ground to ensure that all possible weight and down force is transmitted through the roll, increasing consolidation of moved soil, so conserving soil moisture and crushing any clods that may have been brought to the surface.

## 4.2 Tines

The Flatliner 500 is fitted with with Pro-Lift tines and points. The tines are arranged in a 'V' frame to give lower draft requirements and the ability to work progressively deeper.

Different wings are available to suit the soil conditions and optimise the performance of the machine.

Coarse tine depth is achieved by moving the tines up and down in the adjustable clamps (main working depth is set using the rear roll).

Two additional tines may be added to each machine to reduce the inter-tine spacing.

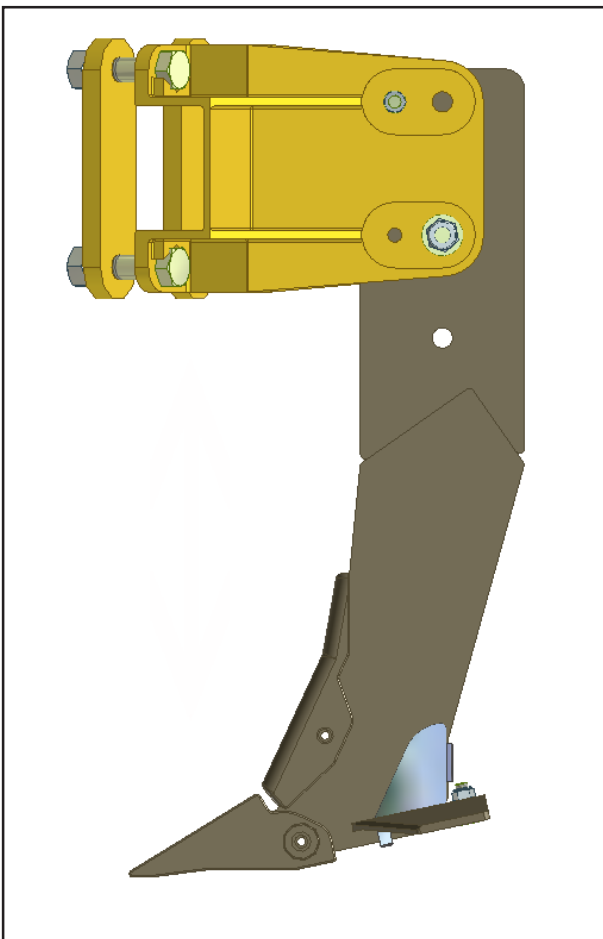

## 4.3 Pro-Lift Wings



**Standard Wing**  
**P09060**

- Maximum soil disturbance with minimum draft requirement under normal circumstances.
- Wing angle reduces wear rates on leg.

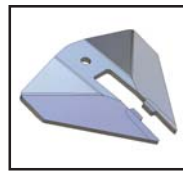

**Extra Lift Wing**  
**P10392**

- Increased lift height and rake angle creates greater soil disturbance on all soil types especially in moister conditions.
- Lower relative distance between edge of wing and point reduces draft requirement.
- Has ability to work at lower depths with no decrease in soil disturbance or risk of smear.

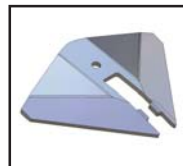

**Extra Wide Wing**  
**P10411**

- Improved lateral shatter in moist/wet soils, or non-cohesive soils.
- Ideal for deep vegetable applications under light/medium soils.

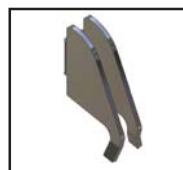

**Wear Shroud**  
**P11181**

- Wear plate to take soil abrasion so lower trailing edge of tine does not wear.

#### 4.4 Double Disc Roller

The standard DD600 roller is made up of individual Double Disc (patented) Ring segments.

The DD rings are designed to consolidate the soil whilst cutting and crushing any clods.

Even in heavy, wet soils it can easily be operated with minimal blockages occurring.

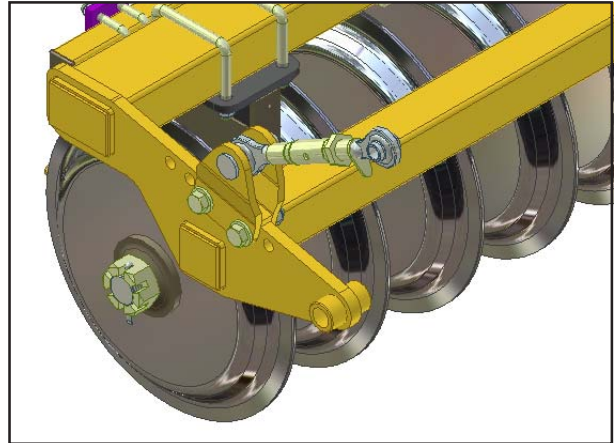

#### 4.5 DD Light Roller

The DD Light roller is made up of individual Double Disc (patented) Ring segments.

The DD Light roll is designed to consolidate the entire soil surface whilst cutting and crushing any clods.

Even in heavy, wet soils it can easily be operated with minimal blockages occurring.

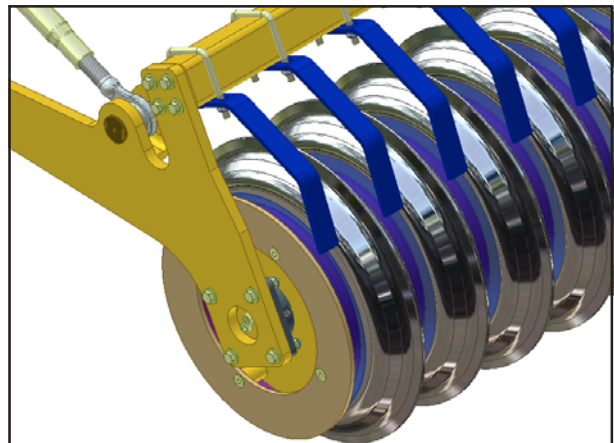

#### 4.6 Scraped Crumbler

The scraped crumbler unit provides a firm and level soil finish which conserves moisture and crushes any clods.

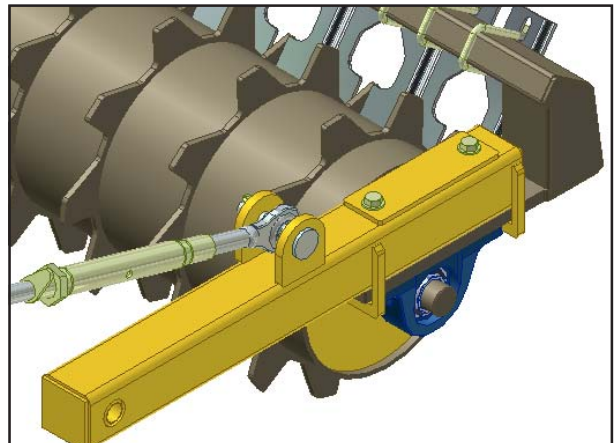

#### 4.7 Aqueel Roll

The SIMBA Aqueel is a polyurethane based specialist self-cleaning tyre. The basic benefit of Aqueeled ground (reservoir tillage) is gained on light, easy working soils that can slump or compact.

The patterned effect left by the Aqueel roll is designed to combat surface water movement and wind erosion in the field.

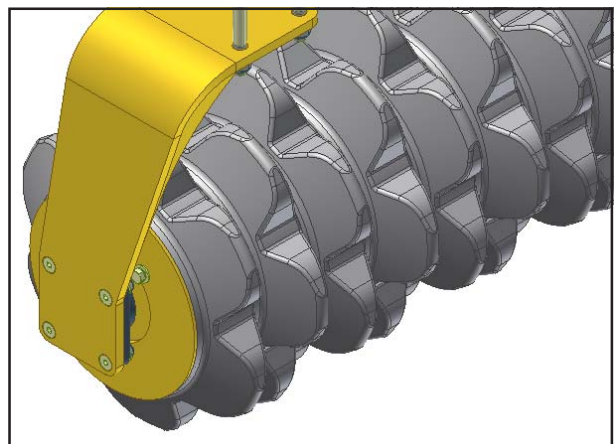

## 4.8 Operation

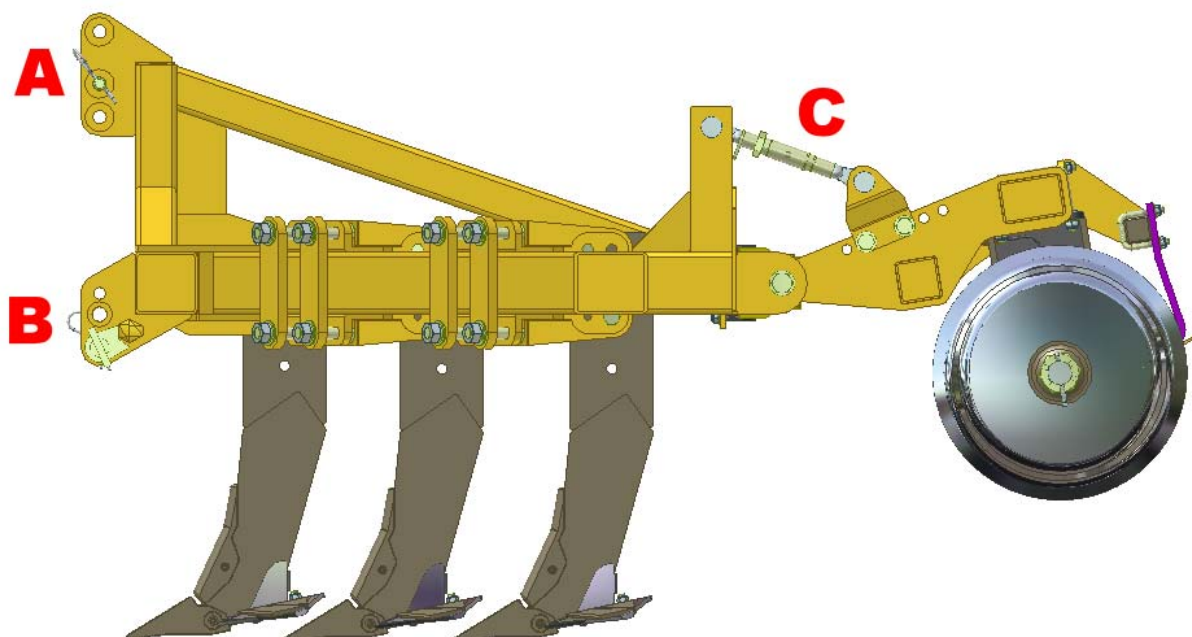

### 4.8.1 Mounted Machines

With the Flatliner 500 mounted on the tractor three-point linkage, lower the machine until the foot of the leading tine is resting on the ground. The trailing tines should be 50 to 125mm clear of the ground, depending on the width of the implement and what the desired operating depth is to be. Set the trailing tines by adjusting the length of the toplink (A).

Once in work the operating depth of the machine has to be controlled by the roll unit or else it will attempt to go deeper. The roll unit is set using the toplink (C).

The roll unit serves two functions; it conserves soil moisture, breaking up any clods left by the tines (not applicable to Aqueels) and limits the operating depth of the machine. The pressure that may be exerted upon the clods by the roll is limited by the weight of the implement and the downward tine thrust. This downward thrust can be increased by fitting wider wings, or slightly increasing the angle

of the points and wings (shortening the toplink - A), and by minimising any draft control setting on the tractor. This is the first area to be investigated, if more crumbler pressure should be required. Draft control can also inhibit initial penetration if the implement is lowered too quickly on the move into work. The rapid increase in draft is sensed by the tractor, which then inhibits further penetration. The solution is to gradually lead the implement into work, thereby not imposing a rapid increase in pulling force.

In most cases where a significant roll pressure is required it is advisable to eliminate draft control if possible.

The Flatliner 500 must run reasonably level or slightly nose down to achieve consistent results across its width and any increase in downward thrust will significantly increase the pull required.

If the crumbler is exerting too much pressure for the conditions, but if raised will cause the machine to operate too deeply, then draft control may have to be used. The operating depth can be controlled to a certain extent by lengthening the tractor top link. This causes the implement to run tail down and reduces the downward thrust on the points and wings, reducing the shattering effect of the tines.

The lowest draught requirement is achieved when the machine is slightly tail down (all points touching the ground at the same time). However the best shattering effect is achieved when the main frame is running level, this attitude being more desirable.

### **Hard/Dry Conditions**

The Flatliner 500 achieves best results in dry conditions but under very hard/dry conditions it may produce large clods of soil at the surface. If the roll unit is unable to break these clods down effectively this may be overcome by removing the tines and increasing the spacing, or an initial precultivation at 50 to 100mm (eg. Disc) depth to eliminate the possibility of forming large clods from soil at this depth.

### **Surface Trash**

The 'V' shape of the Flatliner frame is ideal for fields with surface trash as there are few places for blockages to occur, but under extreme conditions fouling may still be evident. This can be overcome by either increasing the mainframe to ground clearance of the implement (by lowering the tines in their clamps) or by removing some tines if necessary.

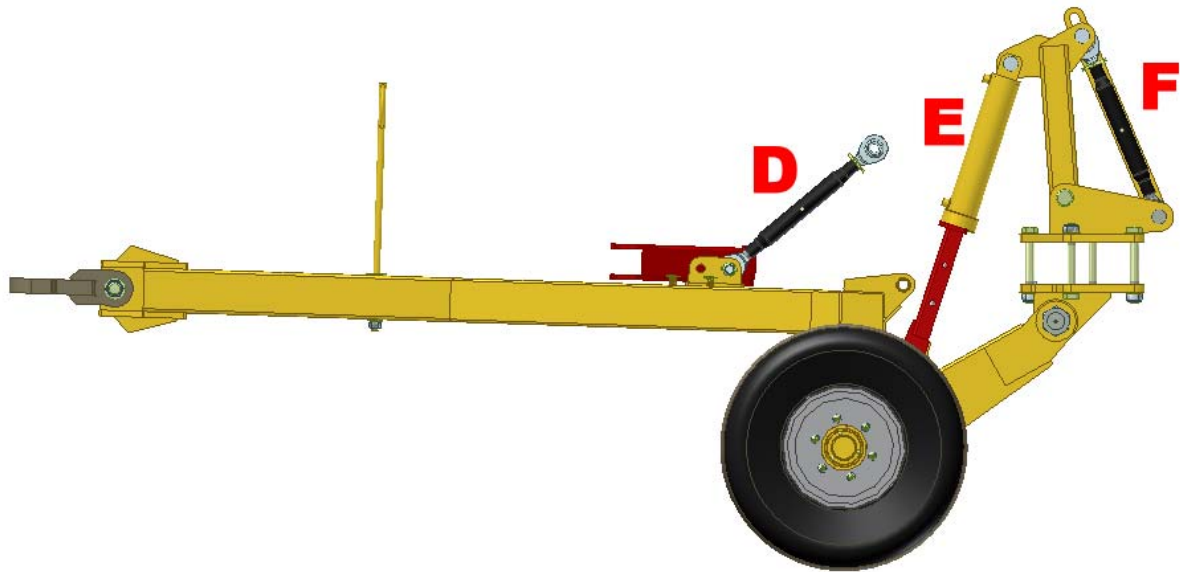

#### 4.8.2 Trailing Kit

The main operating characteristics are identical to the mounted implement. The drawbar may be attached to the tractor rigid drawbar or the pick up hitch. Altering the length of the drawbar top link (D) will raise or lower the back of the frame to alter the draught requirements and quality of work. The drawbar top link may also be used to take account of varying tractor drawbar heights.

Alteration of working depth is effected by altering the length of the top link on each wheel unit (F). Both wheel units must be set to exactly the same length. Remember to check the wheels for clearance after any adjustment. The tie bars should NEVER be removed, therefore should reduced depth still be required when working at the limit of the tie bars; the tines will need to be raised in their clamps.

To adjust working depth proceed as follows: -

Raise the machine and drive forward onto hard ground. Lower the machine fully to eliminate pressure in the hydraulic system.

Retain the hydraulic lever in the 'lower' or 'float' position, then lengthen the adjusters to decrease depth or shorten to increase depth as required.

When entering work ensure that the transport locking units are removed, then lower the tines to the ground, draw forwards until the correct operating depth is achieved. In work the hydraulic cylinders (E) should be in the fully closed position. To leave work, extend the hydraulic cylinders so that the tines are clear of the ground.

## 4.9 Work Instructions

### Driving speed

The Flatliner 500 can be driven at speeds of up to 15 kph.

This depends on the field conditions (type of soil, surface trash, etc.).

Drive more slowly if the conditions are difficult.

Turning:



Before turning, the machine should be eased out of work while driving. Likewise, it should be eased back into work once the turn has been completed.

### Parking the Machine

In order to avoid damage as a result of moisture, the machine should be parked, if possible, indoors or under cover.



When manoeuvring the machine, pay attention to your surroundings. Ensure that nobody (children!) is in the manoeuvring area.

- Park the machine on level and solid ground.
- With the machine raised set the parking stand to the desired height.
- Lower the machine onto the parking stands and the tines, ensuring that it is stable.
- Shut down the tractor.
- Unhitch the machine.

## 4.10 Checks

The working quality depends on the adjustments and checks made prior to and during work, as well as on regular servicing and maintenance of the machine.

Before beginning work it is therefore important to carry out any necessary servicing and to lubricate the machine as required.

### Checks prior to, and during work:

- Is the machine correctly hitched up and the coupling device locked?
- Have the hydraulic lines (if applicable) been connected according to the colour coding?
- Is the machine in a level operating position and the working depth set correctly?

### Working Elements

- Are the tines and other cultivation tools in a serviceable condition?
- Are the scrapers still operable, so that the rolls do not jam?

## 5. Servicing and Maintenance



Follow the safety instructions for servicing and maintenance.



Specialist equipment is required for the disassembly of Double Disc axles / DD Light axles. Please consult your dealer under any circumstances that require disassembly of these axles.

### 5.1 Servicing

Your machine has been designed and constructed for maximum performance, operational efficiency and operator friendliness under a wide variety of operating conditions.

Prior to delivery, your machine has been checked at the factory and by your authorised dealer to ensure that you receive a machine in optimum condition.



To ensure trouble-free operation, it is important that servicing and maintenance work is performed at the recommended intervals.

### 5.2 Cleaning

In order to ensure that the machine is always in operating condition and to achieve optimum performance, perform the cleaning and servicing work at regular intervals.

Avoid cleaning the roll bearings with a high-pressure hose or a direct water jet. The housing, screwed connections and ball bearings are not watertight.

### 5.3 Changing Tine Points and Wings

When changing the tine points and wings it is important to observe safe working practices.

- The machine should be raised and the parking stands should be put into the maintenance setting (see *Fig. 2.01* on Page 16).
- Lower the machine onto the parking stands.
- While still attached to the tractor, the tine points will be clear of the ground allowing for the maintenance to take place.



Do not attempt to assist fitting tine points with a steel headed hammer, as this can lead to splintering of the metal due to it's hardness, which can cause injury. If tine fitting requires assistance, a copper/hide mallet should be used. Wear eye protection.

If parking stands are not fitted:

- Lower the machine onto a level and solid surface.
- With the machine fitted to the tractor, remove the toplinek.
- It is now possible to raise the machine, allowing it to pivot on the 'heels' of the trailing tines so that access to the points is achieved.

## 5.4 Preparation for Storage

If you need to store the machine for a longer period, observe the following points:

- Park the machine undercover if possible.
- Protect the roll against rust. If you need to spray the roll with oil, use light biologically degradable oils, e.g. rape oil.



Cover any rubber sections before using oil sprays. These sections must not be oiled.

Remove any traces of oil with a suitable cleaning agent.

## 5.5 Operator Support

If you have a problem, please contact Your dealer. They will endeavour to solve any problems which may occur and provide you with support at all times.

In order to enable your dealer to deal with problems as quickly as possible, it helps if you can provide them with the following data. Always state the

- Customer Number
- Name and Address
- Machine Model
- Date of Purchase and Operating Hours
- Type of Problem

## 5.6 Maintenance Intervals

Apart from daily maintenance, the maintenance intervals are based on the number of operating hours and time data.

Keep a record of your operating hours to ensure that the specified maintenance intervals are adhered to as closely as possible.

Never use a machine that is due for maintenance. Ensure that all deficiencies found during regular checks are remedied immediately.



Avoid sharp-edged and pointed parts (tine points, etc.) when working on the machine.



Place the machine on suitable supports when working underneath! Do not work under a machine which is not supported!

## 5.7 Maintenance Overview

Flatliner 500 Maintenance Overview			
After first operation	Instructions	Interval	Note
Check all screw, bolt and plug connections	Check they are firmly seated. Tighten / Secure if necessary	---	---
Lubricate machine	See overview of lubricating points	---	Page 29
<b>During operation</b>			
Lubricate machine	See overview of lubricating points	---	Page 29
Upper links and setting spindles	Check setting and ensure they are firmly secured	daily	
Hydraulic system and components	Check seals, signs of crushing/wear, function and condition	daily	
Pro-Lift tines, points and wings.	Check condition, mountings, smooth operation and settings	daily	Page 20
Roll bearings	Check condition, mountings and smooth operation	daily	Page 21
Double Disc roller / DD Light ring segments	Check condition and ensure they are firmly secured	daily	Page 21
Safety devices (Parking stands, transport locks)	Check condition and function	daily	---
<b>After season</b>			
Lubricate machine	See overview of lubricating points	---	Page 29
Toplinks / Bolts	Grease any exposed threads	---	---
Entire machine	Carry out cleaning and maintenance	---	---
Spray Double Disc roll with oil	Use biological oil if possible - cover rubber elements	---	---
<b>After 4 years</b>			
Hydraulic pipes (if applicable)	Replace	MRL Anh I	EN 1533

## 5.8 Overview of Lubricating Points

Flatliner 500 lubrication points	Number	Interval	Diag. No.
DD600 Roll Bearings	4	Daily	7.01
DD Light Bearings	2	End of season	7.02
Scraped Crawler Bearings	2	End of season	7.03
Aqueel Roll Bearings	2	End of season	7.04
Trailing Kit Wheel Pivot Bolt	2	50 hrs.	7.05
Trailing Kit Wheel Bearings	2	50 hrs.	7.06

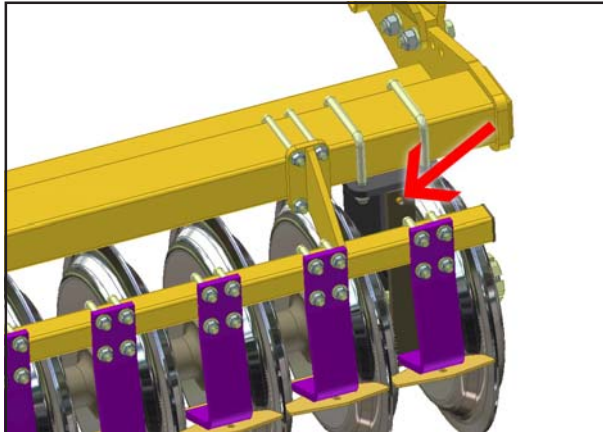

Fig. 7.01: DD Roll Grease Points

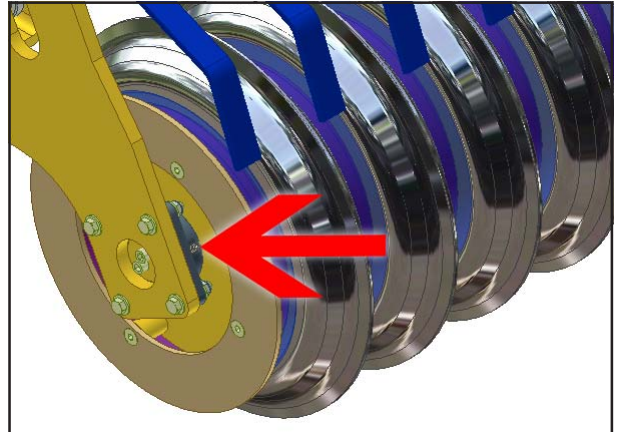

Fig. 7.02: DD Light Grease Points

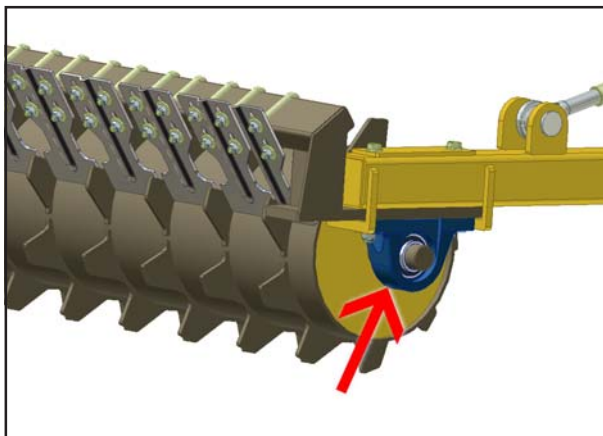

Fig. 7.03: Scraped Crawler Grease Points

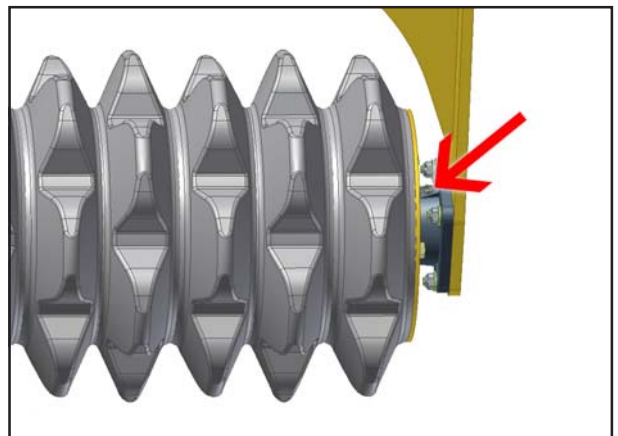

Fig. 7.04: Aqueel Roll Grease Points

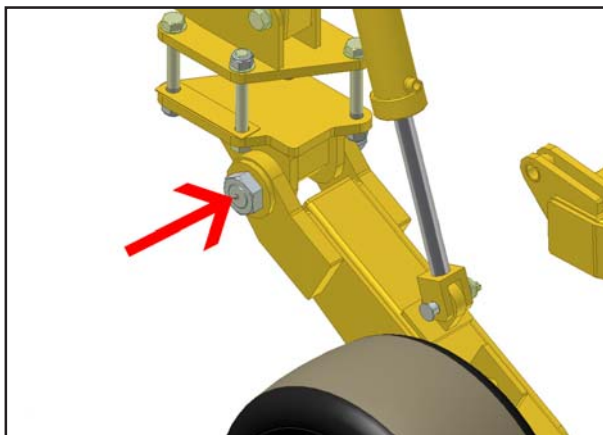

Fig. 7.05: Trailing Kit Wheel Pivot Grease Points

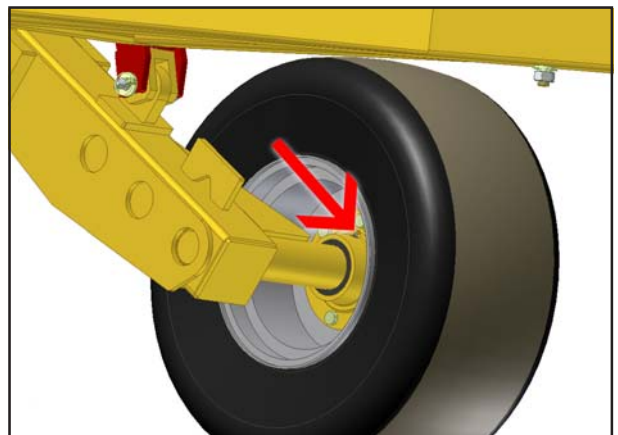

Fig. 7.06: Trailing Kit Wheel Bearing Grease Points

## 5.9 Lubricating the Machine

Please read the section entitled "Using Lubricants" carefully before lubricating the machine.

The machine must be lubricated regularly in order for it to remain serviceable. Regular lubrication also contributes towards extending the service life of your machine.

The recommended lubricating intervals are specified in "Inspection" and "Maintenance Intervals".

After it has been washed using a high-pressure hose or steam cleaned, the machine should always be lubricated using a grease gun. Ensure that the universal joints and splined shafts are lubricated regularly.

### 5.9.1 Handling of Lubricants

Please ensure that you read the following instructions as well as the relevant information. This also applies to any of your employees who handle lubricants.

### 5.9.2 Hygiene

Lubricants do not present a health hazard provided they are used for their specified purpose.

In the case of prolonged skin contact, lubricants - especially low-viscosity oils - may remove the natural layer of fat contained in the skin, resulting in dryness and possible irritation.

It is important to take extreme care when handling waste oil as it may contain other irritants.

Vapours given off by cleaning agents and oils are also a potential health hazard.

You should therefore not carry any oily cloths around. Change soiled work clothing as soon as possible.

Always exercise extreme care and observe

the recommended hygiene rules when handling mineral oil products. Details of these handling regulations can be found in information provided by the health authorities.

### 5.9.3 Storage and Handling

- Always store lubricants where they cannot be accessed by children.
- Never store lubricants in open or unlabelled containers.

#### Fresh Oil:

- Apart from taking the usual care and observing hygiene rules, there is no need to take any special precautions when handling fresh oil.

#### Waste Oil:

- Waste oil can contain harmful contaminants which may cause skin cancer, allergies and other illnesses.

#### Attention!

Oil is a toxic substance. Should you swallow any oil, do not try to vomit. Contact a doctor immediately.

Protect your hands with barrier cream or wear gloves to avoid contact with the skin. Wash off any traces of oil thoroughly with soap and hot water.

- Wash your skin thoroughly with soap and water.
- Use special cleaning agents to clean any dirt off your hands.
- Never wash oil residue from your skin with petrol, diesel fuel or paraffin.
- Avoid skin contact with any oily clothing.
- Do not keep any oily rags in your pockets.
- Wash soiled clothing before wearing it again.
- Ensure that any oily footwear is disposed of in the proper manner.

### **5.9.4 Measures in case of injury through oil**

#### **Eyes:**

Should any oil be splashed into your eyes, rinse with water for 15 minutes. If the eye is still irritated, contact a doctor immediately

#### **If oil is swallowed:**

If oil is swallowed, it is important not to induce vomiting. Contact a doctor immediately.

#### **Skin irritation caused by oil:**

In case of prolonged skin contact, wash off the oil with soap and water.

### **5.9.5 Oil Spills**

Use either sand or a suitable granular absorbent to soak up any spilt oil. Dispose of the oil-contaminated absorbent in the proper manner.

### **5.9.6 Oil Fires**

Never use water to extinguish an oil fire. The oil will float on the water causing the fire to spread.

Burning oil-lubricant must be extinguished using a carbon dioxide powder or foam extinguisher. Always wear respiratory equipment when dealing with fires of this type.

### **5.9.7 Waste Oil Disposal**

Oil-contaminated waste and used oil must be disposed of in accordance with current legislation.

Waste oil must be collected and disposed of in accordance with local regulations. Never pour used oil into unsealed sewage systems or drains or onto the ground.

### **5.9.8 Lubricants & Hydraulic Oil**

#### **5.9.9 Hydraulic System**

The hydraulic fluid from the tractor is mixed with the hydraulic fluid from the machine.

The supplied machine hydraulic system contains Total AZOLLA ZS 32 oil.

#### **5.9.10 Lubricants**

The lubricating points on the machine can be lubricated with multigrade lubricating grease as specified in DIN 51825 KP/2K - 40.

## 6. Faults and Remedies

Flatliner 500		
Fault	Possible cause	Remedy
DD roller does not turn	Bearing seized	Replace bearing
	Scraper misaligned	Re-align scraper
Surface finish is uneven and cloddy	Not enough roll pressure	Reduce draft control
	Wings too aggressive	Fit different wings, either narrower wings or wings with a shallower rake (see page 20)
	Running nose down	Level frame
	Working too shallow	Increase tine depth
All ground not being moved by tines	Working too shallow	Increase tine depth
	Wings not aggressive enough	Fit wider wings
		Fit 2 extra tines
Trailing kit lift cylinders out of phase	Air in hydraulic system	Bleed hydraulic circuit